



PRODUCT CATALOGUE



VENUS INDUSTRIAL CORPORATION Manufacturers & Exporters

424, Industrial Area-A, Ludhiana - 141003 (INDIA)
Tele : +91-161-2221612, 2222955, 2228562
Fax : +91-161-2222954, 2405725

OSHO TOOLS PVT. LTD.

Vill. Jandiali, Chandigarh Road, Ludhiana - 141112 (INDIA)
Tele : +91-161-3297582, 2843638
Fax : +91-161-2843657
web site: www.oshotools.com

VENUS INDUSTRIAL CORPORATION Tapes Division

Vill. Mangarh, Machiwara Road, Ludhiana, Punjab.
Tele: +91 161 2222955, +91 92572 03964
Fax: +91 161 2222954

web site: www.venustools.com e mail: venusexport@satyam.net.in



*The future
is exciting!!*

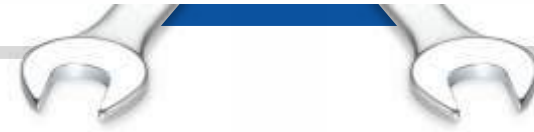

INTRODUCTION

Venus has a very special story of Imagination, Vision & Innovation.

The high standards of quality control throughout the process of taking the raw material to finished product, including testing and inspection, are reflected in the fact that every day, thousands of people around the globe use Venus products.

More than four decades of manufacturing hand-tools with impeccable precision has afforded Venus Industrial Corporation an enviable reputation and place in the industry. Our focus on innovation and use of contemporary technology to make the best tools that provide maximum value to the users has given us an edge, placing us above the rest. Our varied product portfolio includes Spanners, Wrenches, Pliers, Cold Forged Sockets & Sets, Wheel Spanners, Lubrications Tools, OEM Tool Kits

and Measuring Tapes.

We have carved a niche for ourselves as leading manufacturers of Tools, Measuring tapes and various light engineering products in India. Uncompromising quality and exacting specifications are our forte and this is what endows us with the trust of millions.

The passion shown by Venus employees is unique and their care and attention towards each stage ensures quality & consistency.

Our dedicated sales team is always at your service offering support at the highest level.

Today we manufacture 2,00,000 Pcs of Hand Tools daily in facilities spread over 5,00,00 square feet area. We are thankful to more than 2000 families who have helped us in achieving a common goal.

HISTORY

1969 · Venus Group commenced its operations under the aegis Of Mr. Prem Nath Gupta, with only two Drop Forged Hammers.

1989 · Osho Tools Pvt Ltd. Incorporated with seven Drop Forged Hammers

1995 · General Tool Company started, the only socket making company in India by Hot Forging.

2007 · First Forging press line installed from Taiwan to manufacturer professional Hand Tools.

2011 · Three more Forging Press lines installed making Venus the largest hand tool company in India

2012 · Foundation stone laid of state of the art measuring tapes plant imported from Taiwan, Plier and Adjustable Wrench machining lines imported from China.

2013 · Socket machining line imported from Taiwan

Come join the happy family at Venus where the future is exciting.

MANUFACTURING PROCESS

Design & Tool Room



The Tool Room is one of the main strength of manufacturing. We are equipped with assortment of CNC Machining Centres and latest CAD/CAM software's to match complicated design solutions for manufacturing of Forging, Trimming and Coining Dies. This forms the base for achieving consistent quality level and producing same product with high accuracy.

Hot Forging



Our Forging section is equipped with four Forging Presses (Taiwan make) to achieve high accuracy along with 12 Forging Hammers. Our production is based on 'TQM' (Total Quality Management) to guide us for huge assortment of products which are forged with great precision.

Heat Treatment & Quenching



The single most important procedure in the Factory is Heat Treatment, that is very Critical to the strength of every Hand Tool.

Machining



To achieve accuracy in microns machining is done by highly technically qualified employees on CNC & NC Machines.

Surface Finishing & Coating



This is done in house to ensure corrosion protection and surface finishing.

Final Inspection & Packing



All Venus products are 100% inspected by a team of highly experienced staff before dispatch.

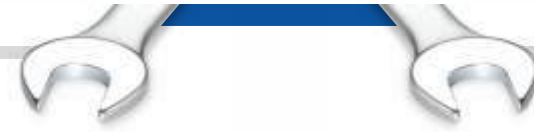

QUALITY

At Venus we strive to build in sufficient reserves to be sure that each product delivers when put to the ultimate test. We achieve this through stringent controls at each stage of production. Our products are GS approved (TUV & VPA), DIN, ANSI compliant & ISI approved (Bureau of Indian Standards).

Quality Policy

At Venus, we have always exceeded the expectation of tool manufacturers and users worldwide. We carefully make each tool under stringent quality control process that are achieved in hi-tech manufacturing environment.

Hardness Testing

Suitably tested on HRC and HRB scales.

Torque Testing

Torque Testing is done by Digitally Controlled Machine that strictly meet International quality Standards like BIS, DIN & ANSI.

Chemical Testing

All raw materials purchased are from renowned steel producers and then further in house tested for exact chemical composition by spectrometer and chemical analysis.

Batch Testing

Batch production means that components stay together through out the manufacturing process

from the moment the raw material is issued from the stores to the moment they pass through final inspection. This ensures complete traceability from the purchase order for the raw material used through to when the product goes into our finished product stores

Inspection

Our Team of inspectors are very experienced. Between them they inspect hundreds of thousands of units. They will pick up any cosmetic, mechanical or manufacturing faults if they appear and then ensure that the necessary corrective action is taken to prevent it happening again. Most product groups are 100% inspected.

Environmental policy

We at Venus continually strive to minimise adverse environment effect on air, water and soil through involvement of all personnel. We are committed to comply with environment health and safety related rules and regulation and other requirements to which we subscribe.

INDEX

• Spanners & Wrenches	8
• Sockets & Accessories	14
• Automotive Tools	18
• Pliers & Pincers	28
• Plumbing Tools	36
• Vices	39
• Measuring Tapes & Tools	44
• Wood Working Tools	50
• Hammers & Striking Tools	53
• Lubrication Tools	58
• Others	60
• Packaging	66

CERTIFICATIONS

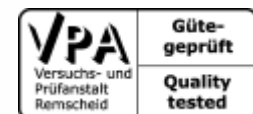



SPANNERS AND WRENCHES

DOUBLE OPEN END SPANNER

V-100

Drop Forged from Carbon Steel/Chrome Vanadium steel with opening set at an of 15° for comfortable approach. Fully hardened and tempered to sustain higher "Torques". The Spanners are based on BIS/DIN/ANSI specifications. Rich Nickel Chrome Plating enhance surface protection and life. Fully polished or matt finish, the ultimate choice is yours!
Whether in bone section or collared head pattern, Venus always does it right!

V-100 Models

- A. Cold Stamped
- B. Satin Finish Full Polish
- C. Chrome Plated Full Polish
- D. Recessed Panel Polished Head (DIN 3110)
- E. Recessed panel Matt Finish
- F. Raised Panel
- G. Matt Finish Elliptical Type
- H. Phosphate Finish (DIN 895)



MM	SAE	WW	Qty/Ctn/Pcs
5.5x7			600
6x7	1/4 x 5/16		600
7x8			600
8x9	5/16x11/32		600
8x10			600
9x10			500
9x11			500
10x11	3/8x7/16	1/8x3/16	500
10x12			500
10x13			500
11x13			500
12x13	7/16x1/2	3/16x1/4	500
10x14			500
12x14			500
13x14			300
14x15	1/2x9/16	1/4x5/16	300
13x17			250
14x17			250
16x17	19/32x11/16	5/16x3/8 5/16x7/16	250 200
17x19			200
18x19	5/8x3/4	3/8x7/16	200
19x21			150
19x22			150
20x22	13/16x7/8	7/16x1/2	150
21x23			100
22x24			100
		7/16x9/16	100
24x26	15/16x1	1/2x9/16	100
24x27			100
25x28	1x1-1/8	9/16x5/8 9/16x11/16	75 60
27x30			60
27x32		5/8x3/4	60
30x32	1-1/8x1/4	11/16x3/4	60
32x36		3/4x7/8	30
36x41		7/8x1	30
41x46		7/8x1-1/8	24
46x50			20
50x55			20
55x60			20

Std. Pkg/Ctn. is for recessed panel. Other models may vary.

.....Also available in sets

SETS	Qty/Ctn/Pcs
6 Pc Set 6-17mm	50
8 Pc Set 6-22mm	40
12 Pc Set 6-32mm	15

Sets also made to specific requirement
Also available in Black Phosphate finish

COMBINATION SPANNER

V-101

Drop Forged from Carbon Steel/Chrome Vanadium steel. The open end set at 15° and ring end finely machined for perfect geometry. Nickel chrome plated for enhanced life and appearance. Spanners are available in polished and matt finish. The product is based on BIS/DIN/ANSI specifications.

MM	SAE	Qty/Ctn/Pcs
6	1/4	1000
7		1000
8	5/16	500
9	11/32	500
10	3/8	500
11	7/16	500
12		400
13	1/2	250
14	9/16	250
15	19/32	250
16	5/8	250
17	11/16	200
18		150
19	3/4	150
20		100
21	13/16	100
22	7/8	100
23		100
24	15/16	100
25	1	50
26		50
27	1-1/16	50
28		50
29	1-1/8	50
30		50
32	1-1/4	50
33		50
34		50
36		50
38		50
41		40
46		40
50		25

Std. Pkg/Ctn. is for recessed panel. Other models may vary.

5 Pc. SETS	Qty/Ctn/Pcs
3/8, 7/16, 1/2, 9/16, 5/8 SAE	60
6 Pc. SETS	Qty/Ctn/Pcs
8, 10, 12, 13, 14, 17mm	60
8 Pc. SETS	Qty/Ctn/Pcs
8-11, 13, 14, 17, 19mm	36
12 Pc. SETS	Qty/Ctn/Pcs
6-14, 17, 19, 22mm	20
14 Pc. SETS	Qty/Ctn/Pcs
8-17, 19, 21, 22, 24mm	20
26 Pc. SETS	Qty/Ctn/Pcs
6-30, 32mm	4

V-101 Models

- A. Cold Stamped
- B. Satin Finish Full Polish
- C. Full Polished Chrome plated Elliptical type
- D. Recessed Panel Polished Head (DIN 3113)
- E. Matt Finished Elliptical Type
- F. Raised Panel
- G. Stubby Full Polished



Also available in sets to specific requirement

BI-HEXAGONAL RING SPANNERS

Drop Forged from Carbon Steel/Chrome Vanadium steel hardened and tempered to sustain higher "Torques". Finely machined Bi-Hexagonal serrations are geometrically perfect to reach faster for a uniform grip. The Spanners are based on BIS/DIN/ANSI standards. Rich Nickel Chrome Plating enhance surface protection & life.

V-100 Models

- A. Cold Stamped
- B. Satin Finish Full Polish
- C. Chrome Plated Full Polish
- D. Recessed Panel Polished Head (DIN 838)
- E. Recessed panel
- F. Matt Finish Elliptical type
- G. Recessed Panel Shallow Type



MM	SAE	WW	Qty/Ctn/Pcs
6x7	1/4 x 5/16		300
6x8			300
8x9			300
8x10			300
10x11	3/8x7/16	1/8x3/16	250
10x12			250
10x13			250
12x13		3/16x1/4	200
12x14			200
13x14			200
13x16			150
14x15	1/2x9/16	1/4x5/16	150
14x17		5/16x3/8	100
15x17			100
16x17	5/8x11/16		100
17x19			100
18x19	3/4x25/32		100
		5/16 x 7/16	100
		3/8 x 7/16	100
19x22			60
20x22	13/16x7/8		60
21x23			50
22x24			50
24x26			50
24x27	15/16x1	1/2x9/16	50
25x28		9/16x5/8	40
27x30			40
27x32		9/16x11/16	40
30x32	1-1/16x1/4	5/8x3/4	40
32x36		3/4x7/8	15
36x41		7/8x1	15
41x46		7/8x1-1/8	10
46x50			10
50x55			8
55x60			8

.....Also available in sets

SETS	Qty/Ctn/Pcs
6 Pc Set 6-17mm	25
8 Pc Set 6-22mm	20
12 Pc Set 6-32mm	8

Sets also made to specific requirement



SINGLE ENDED SPANNER

Drop Forged from Carbon Steel/Chrome Vanadium steel based on DIN- 894. Fully Hardened and tempered to sustain higher torques. Comfortable shank grip which ensures perfect wrecking action.

MM	Qty/Ctn/Pcs	MM	Qty/Ctn/Pcs
6	1000	32	50
7	1000	34	50
8	600	36	40
9	600	38	30
10	500	41	30
11	500	46	20
12	500	50	20
13	500	55	15
14	500	60	15
15	500	65	10
16	500	70	10
17	400	75	10
18	400	80	10
19	400	85	10
21	200	90	10
22	200	95	10
23	200	100	10
24	80	105	10
25	80	110	10
27	80	115	10

› Available in Phosphate, Zinc & Bright Chrome finish



SLOGGING WRENCH (A) Open End (B) Ring End

› Drop Forged from Chrome Vanadium steel. Fully Hardened and tempered to sustain higher torques. Available in Black Finish

Sizes: 22, 24, 27, 30, 32, 34, 36, 38, 41, 46, 50, 55, 60, 65, 70, 75, 80, 85, 90, 95, 100, 105, 110

Also available in Std Packing.



ADJUSTABLE WRENCHES

Drop forged from special tough steel duly hardened and tempered. Moving jaw guide clearly machined for effortless operation. Available in nickle chrome finish and Black finish.

MM	INCHES	Qty/Ctn/Pcs
150	6	100
200	8	60
250	10	48
300	12	36
375	15	20

Also available in malleable casting.





SOCKETS AND ACCESORIES



First in INDIA to make Cold Forged Sockets

Cold Forged Sockets

V-106

- > 1/2" square drive MM size.
- > Chrome vanadium Steel, Hardened & tempered.
- > Chrome plated, Fully Polished.
- > Hex/Bi-hexagonal sockets.

MM	WW	Qty/Ctn/Pcs
8, 9, 10, 11	1/8, 3/16	300
12, 13, 14, 15, 16	1/4, 5/16	300
17, 18, 19		240
21, 21, 22	3/8, 7/16	180
23, 24	9/16	160
25, 26		160
27		120
28		120
29		120
30, 32, 33, 34	11/16	75

Square Drive Ratchet Handle

V-107

- > Chrome vanadium Steel, Hardened & tempered.
- > Chrome plated, Fully Polished.
- > Ergonomic grip

MM	INCHES	Qty/Ctn/Pcs
250	10	25

Sliding Bar

V-108

MM	Qty/Ctn/Pcs
290	60

Extensions

V-109

- > Chrome vanadium Steel, Hardened & tempered.
- > Chrome plated, Fully Polished.

MM	INCHES	Qty/Ctn/Pcs
75	3	120
125	5	120
250	10	60

Speed Brace

V-110

- > Chrome vanadium Steel, Hardened & tempered.
- > Chrome plated, Fully Polished.

1/2" Universal Joint

V-111

L Handle

V-112

MM	INCHES	Qty/Ctn/Pcs
175	7	60
220	9	50
300	12	40
450	18	16

T Socket Spanner

V-113

MM	Qty/Ctn/Pcs
8	60
9	60
10	60
11	60
12	60
13	60
14	60
15	60

24 Pcs. Socket Wrench Set (Steel Casing)

V-114

- > 1/2" Square drive MM/SAE size.
- > Chrome vanadium steel, hardened & tempered.
- > Chrome plated, fully polished.

18 Pcs. in a set 10, 11, 12, 13, 14, 15, 16, 17, 18, 19, 20, 21, 22, 23, 24, 27, 30, 32mm	1/2" Square Drive.
Extension Bar	125mm
Sliding Bar	250mm
Speed Brace	
Reversible Ratchet Handle	250mm
Extension Bar	250mm
Universal Joint	

32 Pcs. Socket Wrench Set (Plastic Casing)

V-115 A

19Pcs 1/2" Dr. Socket	8, 9, 10, 11, 12, 13, 14, 15, 16, 17, 18, 19, 20, 21, 22, 24, 27, 30, 32
6Pcs 1/2" Dr. Socket 12Pt	10, 12, 14, 15, 17, 19mm
2Pcs 1/2" Dr. Spark Plug Socket	16, 21mm
2Pcs 1/2" Dr. Extension Bar	5", 10"
1Pcs 1/2" Dr. Universal Joint	
1Pcs 1/2" Dr. Ratchet Wrench	
1Pcs 1/2" Dr. 3 way Adaptor	

20 Pcs. Socket Wrench Set (Plastic Casing)

V-115 B

12Pcs 1/2" Dr. Socket	10, 11, 12, 13, 14, 15, 16, 17, 18, 19, 22, 24mm
3Pcs 1/2" Dr. Deep Socket	13, 17, 19mm
1Pcs 1/2" Dr. Ratchet wrench	
1Pcs 1/2" Dr. Extension Bar	10"
1Pcs 1/2" Dr. 3 Way Adaptor	
1Pcs 1/2" Dr. Spark Plug Socket	16mm
1Pcs 1/2" Dr. Universal Joint	

AUTOMOTIVE TOOLS



WHEEL SPANNER (Solid box type) V-116

- Drop Forged from Carbon Steel / Chrome Vanadium steel/EN-19.
- Hardened for efficient performance.
- Available in Chrome Plated / Black finish / Zinc finish

MM	SAE	Length MM	Qty/Ctn/Pcs
24x27	15/16 x 1-1/16	400	8
27x27	1-1/16 x 1-1/16	400	8
27x30	1-1/16 x 1-3/16	400	8
27x32	1-1/16 x 1-1/4	400	8
27x33	1-1/16 x 1-5/16	400	8
30x30	1-3/16 x 1-3/16	400	8
30x33	1-3/16 x 1-5/16	400	8
33x33	1-5/16 x 1-5/16	400	8
21x38		400	8
21x41		400	8



V-117

TOMMY BAR

- Also available in Chrome Plated / Black Finish
- Different Lengths available starting 400mm onwards



V-118

TELESCOPIC TYPE BAR

- Also available in Chrome Plated / Black Finish

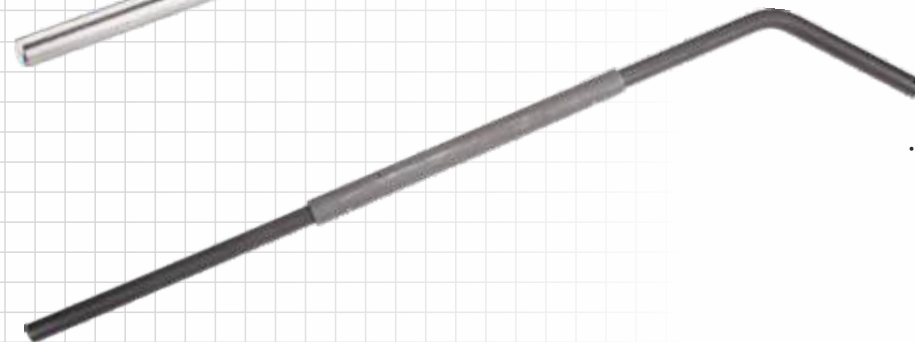

V-119

CROSS WHEEL SPANNERS

- Drop forged from selected grade steel.
- Available in Chrome Plated/Powder Coated/Black Finish

MM	17 x 19 x 21 x 23
SAE	13/16 x 11/16 x 7/8 x 3/4

L-Inch	MM	Qty/Ctn/Pcs
13	330	20
14	350	20
15	375	20
16	400	20
18	450	16
20	500	10

- Rod Dia Available From 13mm onwards

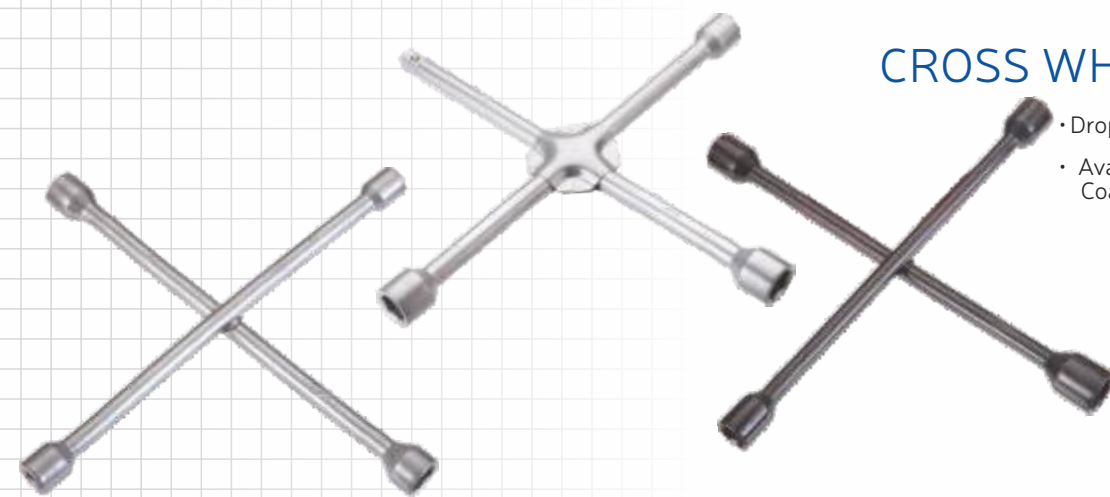

V-120

TUBULAR BOX SPANNERS DOUBLE END with Tommy bar

(A) Hollow tube (B) Zinc Plated

- Available in Various Length & Gauges
- Tommy Bar 8mm x 140mm
- Also available Drop Forged

MM	Qty/Ctn/Pcs	MM	Qty/Ctn/Pcs
6x7	800	18x19	100
8x9	500	20x22	100
10x11	400	21x23	80
12x13	300	24x26	60
14x15	300	25x28	60
16x17	200	30x32	60



V-121

PLUG SPANNER SWIVEL HEAD

- Zinc Plated
- *Other sizes Available to specific requirement

MM	Qty/Ctn/Pcs
16	80
21	80



V-122

BOX SPANNER Jumbo Size

- Zinc Plated

MM
50
60
85

Available In Standard Packing

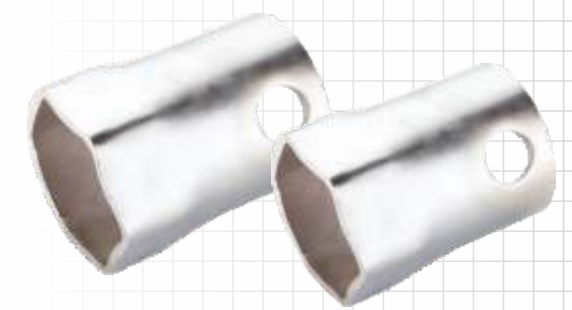

V-123

DOUBLE SOCKET L-SPANNER (Solid Type)

- › Forged from Carbon steel
- › Fully Heat treated
- › Zinc Plated

SIZES: 6, 7, 8, 9, 10, 11, 12, 13, 14, 15, 16, 17, 18, 19, 20, 21, 22, 23, 24, 25, 26, 27, 28, 29, 30, 32

Available In Standard Packing

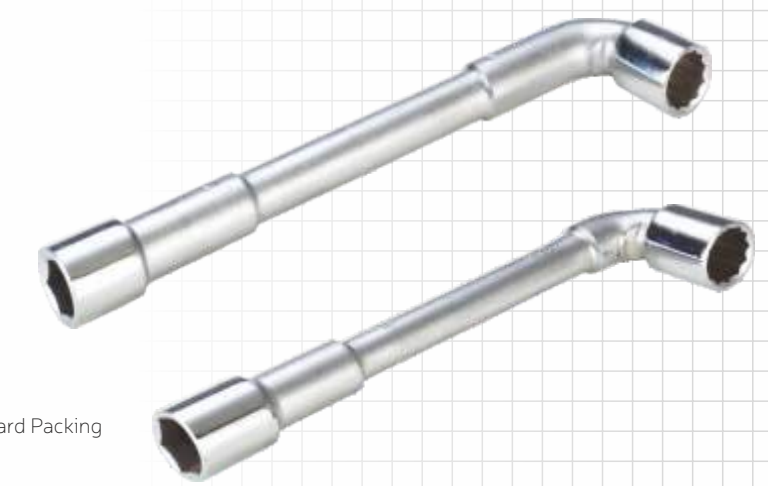



SOLID BOX SPANNER V-124

- › Made from Carbon Steel / Chrome Vanadium
- › Fully Heat treated

SIZES: 6x7, 8x9, 10x11, 12x13, 14x15, 16x17, 18x19, 20x22, 21x23, 24x27, 25x28, 30x32



ANGULAR WHEEL SPANNERS (L-TYPE) V-125

- Chrome Plated, Zinc or Black finish. • Available with or w/o slot.

MM	SAE	Qty/Ctn/Pcs
17	11/16	40
19	3/4	40
21	13/16	40
23	7/8	40



TYRE LEVER / TYRE CROW BAR V-126

- Drop forged from Chrome Vanadium Steel
- Hardened & tempered for higher loads.
- Length 450mm



BEARING PULLER 2 JAWS V-127

- › Drop Forged from selected carbon steel duly hardened & tempered.
- › Ideal for removing gear wheels, pulleys ball bearing etc.

MM	INCHES	Qty/Ctn/Pcs
75	3	50
100	4	40
150	6	24
200	8	16
250	10	12
300	12	8



BEARING PULLER 3 JAWS V-128

- › Drop Forged from selected carbon steel duly hardened & tempered.
- › Ideal for removing gear wheels, pulleys ball bearing etc.

MM	INCHES	Qty/Ctn/Pcs
75	3	40
100	4	32
150	6	16
200	8	12
250	10	8
300	12	8



V-129 A

OIL FILTER WRENCH Light duty

- › Selected carbon steel with chain type adjustment.

SIZE	Qty/Ctn/Pcs
Std.	160

V-129 B

OIL FILTER WRENCH Heavy duty

- › Selected carbon steel with Heavy firm plastic grip.

SIZE	Qty/Ctn/Pcs
Std.	60



V-130

TOOL BOX

A) Single stage

- › Suitable for Plumbers.
- › Convenient to move.

B) 3 stage

- › Venus Tool Boxes are of sturdy steel sheet having collapsible chest with handle. Content of tool box are according to customer requirements.
- › Capacity upto 20 Kgs

C) 5 stage

- › Venus Tool Boxes are of sturdy steel sheet having collapsible chest with handle. Content of tool box are according to customer requirements.
- › Capacity upto 30 Kgs

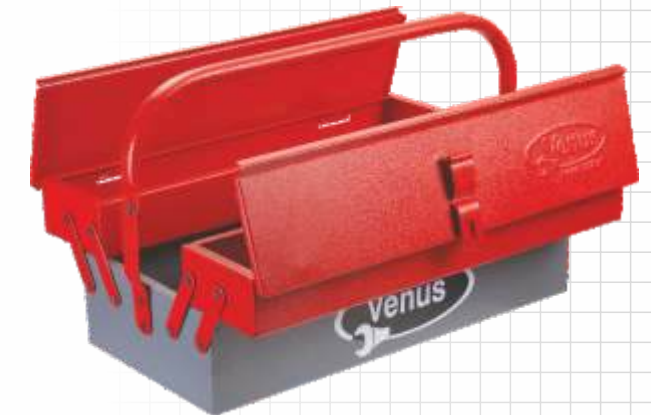

V-131

TOOL TROLLEY

- › Venus Tool Boxes are of sturdy steel sheet having collapsible chest with handle. Content of tool box are according to customer requirements.
- › Available in 3 stage / 2 stage chest / with box lock and key in various colors.





TWO WHEELER KITS

V-132 A

Screw Driver Grip
Screw Driver Rod
Pin Spanner
Tubular Spanner



V-132 B

Tubular Spanner
Tommy Bar
Grip
Rod
D.O.E Spanner



V-132 C

Grip
Rod
Eye wrench
D.O.E Spanner
Tubular Spanner

CAR KITS

V-133 A

L Spanner
Tow Hook



CAR KITS

V-133 B

Grip
Rod
Jack Handle
L Type Spanner
D.O.E Spanner



V-133 C

Screw Driver
L Type Spanner
Tow Hook
Tubular Spanner
Handle For Key
Screw Driver
D.O.E Spanner

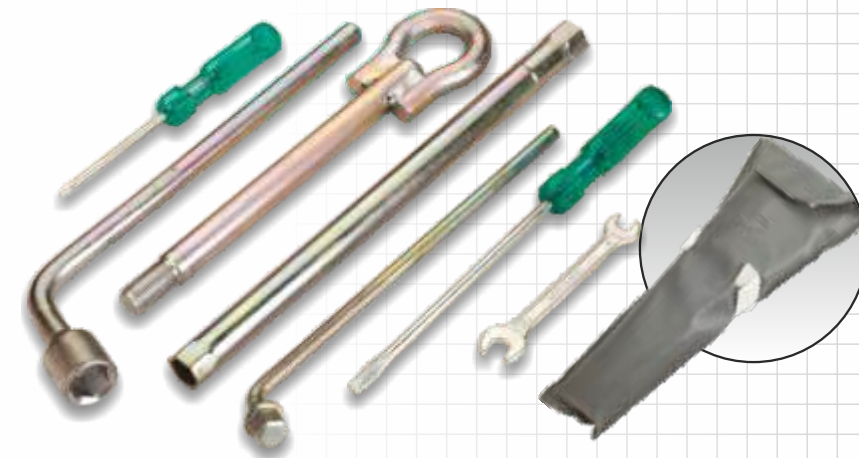

COMMERCIAL VEHICLE KITS

V-134A

L Handle
Ring Spanner
Tyre Lever
Wheel Spanner
D.O.E Spanner

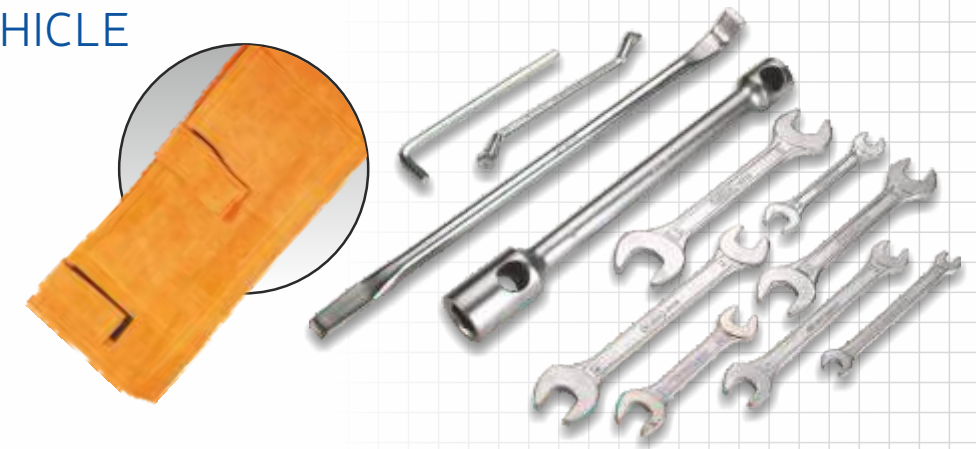

V-134 B

D.O.E Spanner
Wheel Spanner
Grip
Rod





TRACTOR/ AGRICULTURE RANGE

V-135 A

- D.O.E Spanner
- Grease Gun With Coupler
- Screw Driver
- Ring Spanner
- Plier



V-135 B

- Screw Driver
- Grease Gun
- Ring Spanner
- D.O.E Spanner
- Allen Key



V-135 C

- Screw Driver
- Ring Spanner
- Wheel Spanner
- Tommy Bar
- D.O.E Spanner
- Slip Joint Plier



AUTO COMPONENTS

V-136

- Scissor Jack With Handle
- Door Hinge
- Screw Jack With Rod
- Side Cutter
- Anti Roll Bar
- U Bolt
- Shackle Pin
- Swing Fork
- Lever

EARTH MOVING EQUIPMENT RANGE

V-137 A

- D.O.E Spanners
- Allen Keys
- Sliding Bar
- D.O.E Spanner
- Plier
- Ring Spanner
- Socket
- Screw Driver



V-137 B

- Tool Box
- Filter Wrench
- Screw Driver
- Sockets
- D.O.E Spanner
- Hammer
- Slip Joint Plier
- Extension Bar
- Ratchet
- Adjustable Wrench



V-137 C

- Wheel Spanner
- D.O.E Spanner
- Single Ended Spanner
- Plier
- Allen Key
- Adjustable Wrench
- Hammer
- Screw Driver
- Ring Spanner
- Grease Gun





**PLIER &
PINCERS**



COMBINATION PLIERS

V-138 A

Drop Forged from Carbon Steel/Chrome Vanadium steel. Efficient side cutting feature and induction hardened edge enhance life. Handles are fitted with moulded sleeve of various color, choice and texture.

MM	INCHES	Qty/Ctn/Pcs
150	6	120
175	7	96
200	8	72



Combination Plier made from Carbon Vanadium & Polished. Cutters Induction hardened Sleeves made of virgin acetate & randomly inspected for electric shock.

V-138 B

MM	INCHES	Qty/Ctn/Pcs
200	8	60



Combination Plier, Polished with two-colour insulation sleeve.

V-138 C

MM	INCHES	Qty/Ctn/Pcs
150	6	120
175	7	96
200	8	72



LONG NOSE PLIER

V-139

Drop Forged from Carbon / Chrome Vanadium steel with Fine serrations enabling firm grip. Jaws duly hardened and tempered with durable sleeves of your choice.

(A) CRV steel and acetate sleeve
(B) Carbon steel

MM	INCHES	Qty/Ctn/Pcs
150	6	120
175	7	96
200	8	60



RADIO NOSE PLIER

V-140

> Long Slim Nose with Shearing Cutter,
> Induction Hardened,
> Serrated Gripping Surface

MM	INCHES	Qty/Ctn/Pcs
150	6	100



SIDE CUTTING PLIER

V-141

Drop Forged from Carbon / Chrome Vanadium steel with cutting edge induction hardened. Available in polished as well as chrome plated finish with sleeves of various textures.

MM	INCHES	Qty/Ctn/Pcs
150	6	120
175	7	96
200	8	60

(A) CRV steel and acetate sleeve
(B) Carbon steel



V-142

FENCE PLIERS HAMMER HEAD TYPE

> Multi function with hammer head
> Drop forged from Carbon / Chrome vanadium steel.
> Hardened and tempered.

MM	INCHES	Qty/Ctn/Pcs
250	10	36



V-143

FENCE PLIERS STRAIGHT TYPE

> Drop forged from Carbon / Chrome vanadium steel.
> Hardened and tempered with dip insulation.

MM	INCHES	Qty/Ctn/Pcs
250	10	36
300	12	36

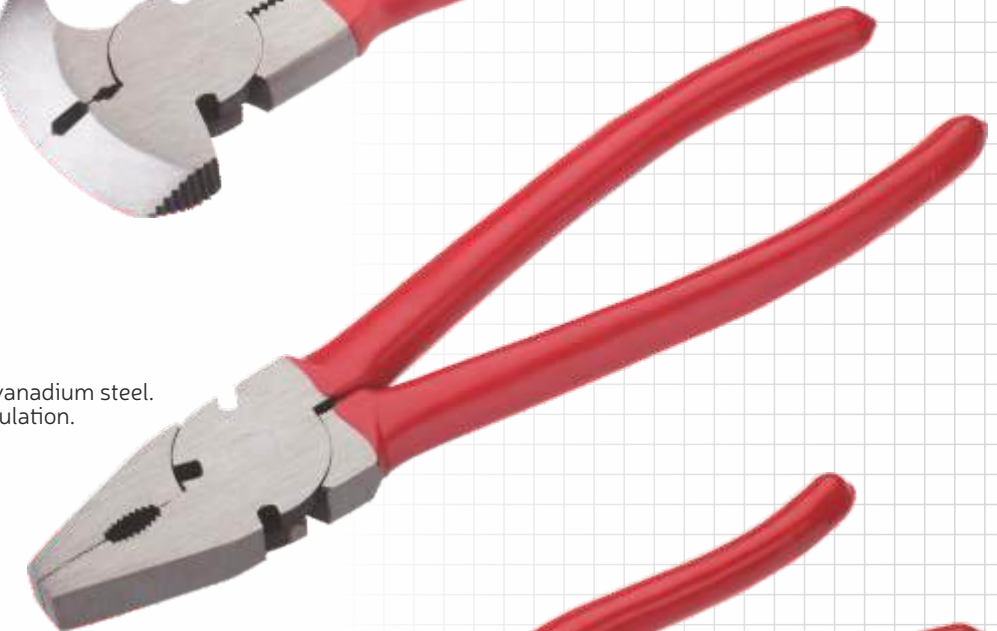

V-144

COMBINATION PLIER KLIEN TYPE

> Drop forged from Carbon / Chrome vanadium steel.
> Hardened and tempered with dip insulation.

MM	INCHES	Qty/Ctn/Pcs
230	9	36

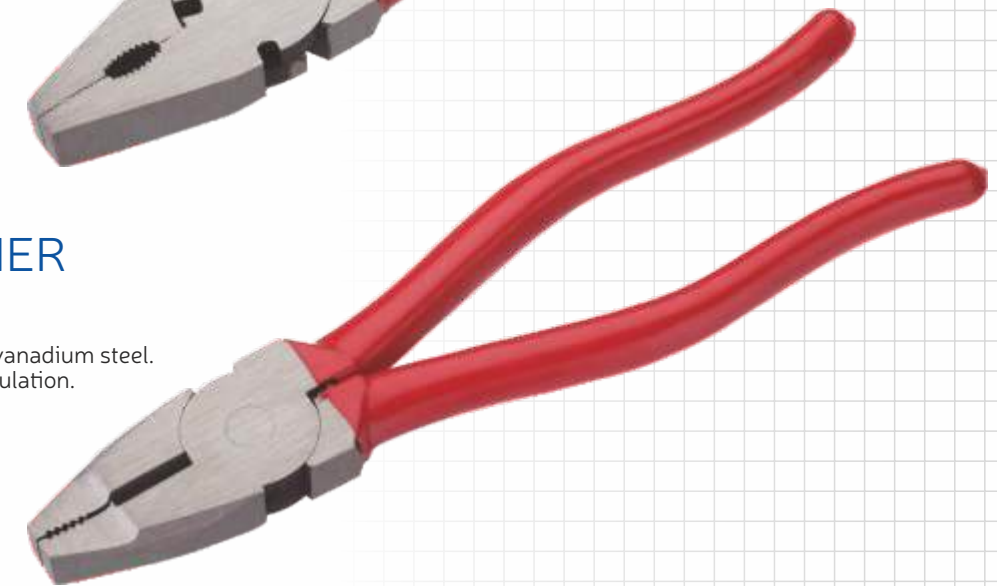

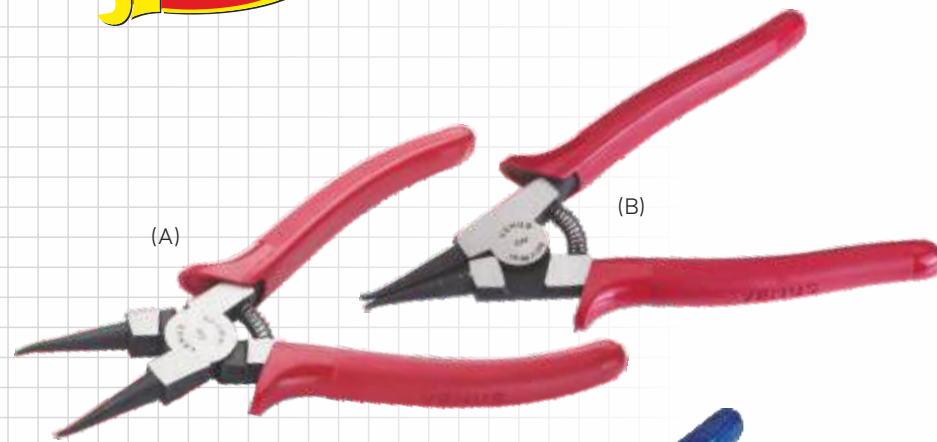

V-145

CIRCLIP PLIERS Straight Nose

› Drop Forged from Chrome Vanadium steel duly heat treated. Available internal / external with spring & cushioning grip.

MM	INCHES	Qty/Ctn/Pcs
175	7	60

(A) External (B) Internal

V-146

CIRCLIP PLIERS Bent Nose

› Drop Forged from Chrome Vanadium steel duly heat treated. Available internal / external with spring & cushioning grip.

MM	INCHES	Qty/Ctn/Pcs
175	7	60

(A) External (B) Internal

V-147

WIRE STRIPER

› For Electronics, Automobile & Telecommunication Technicians

MM	INCHES	Qty/Ctn/Pcs
150	6	200

V-148

CABLE CUTTER

› For Electronics, Automobile & Telecommunication Technicians

MM	INCHES	Qty/Ctn/Pcs
150	6	200

V-149

BOLT CUTTER

› Drop Forged Alloy Steel
› Hardened & Tempered

MM	INCHES	Qty/Ctn/Pcs
200	8	60
300	12	15
350	14	15
450	18	12
600	24	8



V-150

WATER PUMP PLIERS SLIP JOINT

› Drop Forged from Chrome Vanadium/Carbon Steel.
› Hardened and Tempered.
› Serrated jaws and ribbed handles for slip free grip

MM	INCHES	Qty/Ctn/Pcs
250	10	60
300	12	40

V-151

WATER PUMP PLIERS BOX JOINT

› Drop Forged from Chrome Vanadium/Carbon Steel.
› Hardened and Tempered.
› Serrated jaws and ribbed handles for slip free grip

MM	INCHES	Qty/Ctn/Pcs
250	10	60
350	14	36

V-152

WATER PUMP PLIERS GROOVE JOINT

› Drop Forged from Carbon Steel.
› Hardened and Tempered.
› Precision groove joints enable smooth positioning and firm grip.
› Available with & w/o grip.

MM	INCHES	Qty/Ctn/Pcs
200	8	100
250	10	60
300	12	40

V-153

LOCK GRIP PLIERS

› Drop forged Jaw from Carbon / Chrome vanadium steel.
› Body made of robust steel handles and release lever.
› Effortless working of head screw facilities fine adjustment.
› Nickel Chrome Plated.

MM	INCHES	Qty/Ctn/Pcs
125	5	160
175	7	80
250	10	50

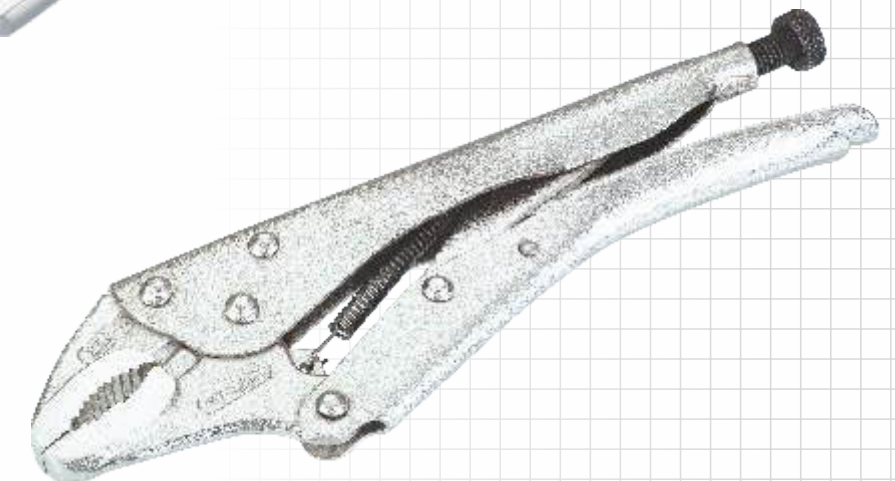



(A)



(B)

SLIP JOINT PLIER V-154

› Drop forged from Carbon / Chrome vanadium steel duly hardened and tempered. Available with or w/o insulation and in polished or matt texture.

MM	INCHES	Qty/Ctn/Pcs
150	6	100
200	8	100
250	10	72

(A) with Sleeve (B) without Sleeve

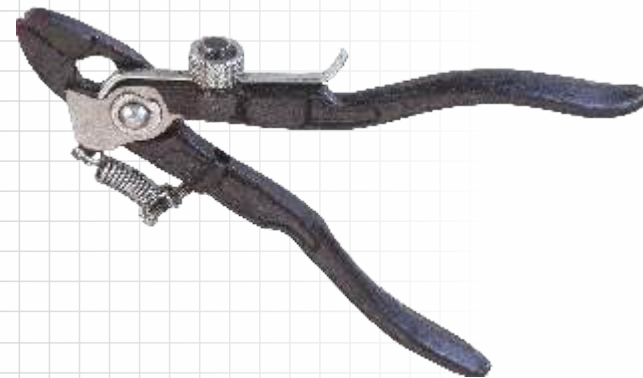

SAW SET PLIER V-155 GERMAN TYPE

› Drop Forged/Black Painted.

MM	INCHES	Qty/Ctn/Pcs
175	7	120

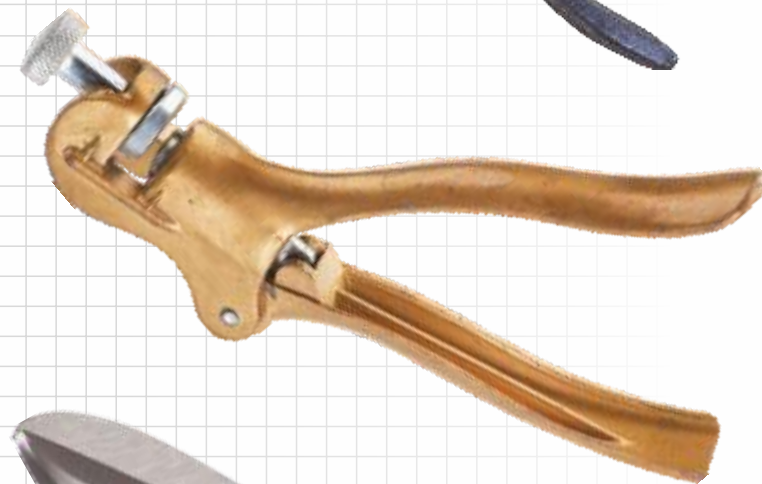

SAW SET PLIER V-156 PISTOL TYPE

› Made from aluminum die casting and painted.

MM	INCHES	Qty/Ctn/Pcs
175	7	100



V-157

TIN CUTTING PLIER

› Drop forged from carbon steel, duly hardened with or w/o spring.

MM	INCHES	Qty/Ctn/Pcs
150	6	100
200	8	60
250	10	60
300	12	60
350	14	30
400	16	30
600	18	20

V-158

TOWER PINCER PLIERS

› Drop forged pincer pliers made from Carbon steel.
› Cutting head duly hardened and tempered.
› Available with and w/o sleeves
A) without Sleeve
B) with Dip Sleeve
C) with Nail Puller

MM	INCHES	Qty/Ctn/Pcs
225	9	72
250	10	72
300	12	40



(A)

(B)

(C)

V-159

TOP CUTTING PLIERS

› Drop forged top cutting pliers made from Carbon steel.
› Cutting head duly hardened and tempered.
› Available with / without Sleeve

MM	INCHES	Qty/Ctn/Pcs
150	6	120
175	7	100



V-160

COBLER PINCER PLIERS

› Drop forged Cobler pliers made from Carbon steel.
› Cutting head duly hardened and tempered.

MM	INCHES	Qty/Ctn/Pcs
150	6	76
175	7	72
200	8	60



V-161

CARPENTER PINCER PLIERS

› Drop forged Carpenter pliers made from Carbon steel.
› Cutting head duly hardened and tempered.
› Available with / without Sleeve

MM	INCHES	Qty/Ctn/Pcs
150	6	96
175	7	72
200	8	60



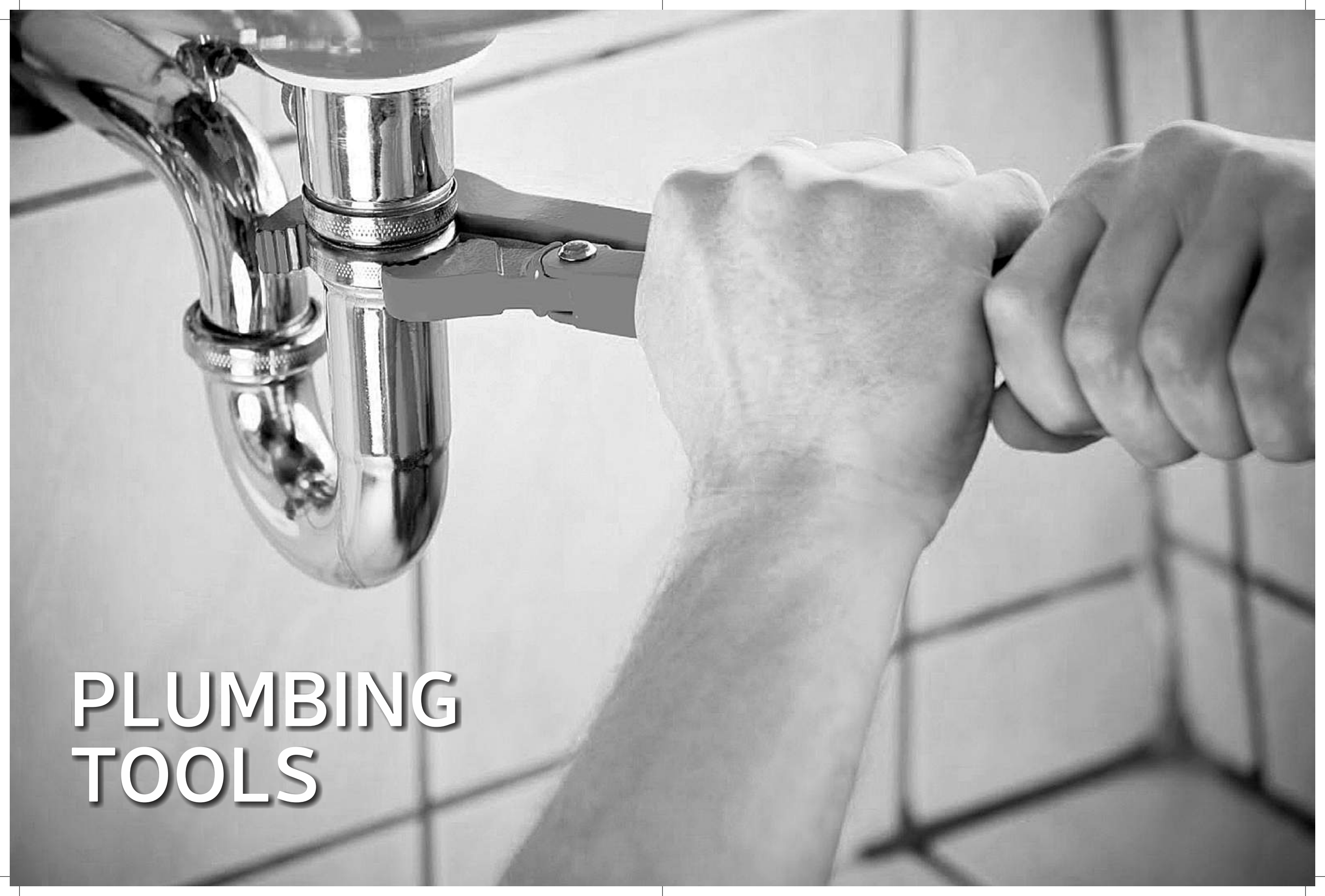

PLUMBING TOOLS



PIPE WRENCH V-162

Stillson pattern Venus Premium

	MM	INCHES	Qty/Ctn/Pcs
› Venus Brand premium wrench drop forged special ISI specified steel Hardened & tempered to withstand static / stock loads with high torques.	200	8	80
	250	10	40
	300	12	25
	350	14	20
	450	18	12
	600	24	6
	900	36	4
› with Steel Housing	1200	48	2

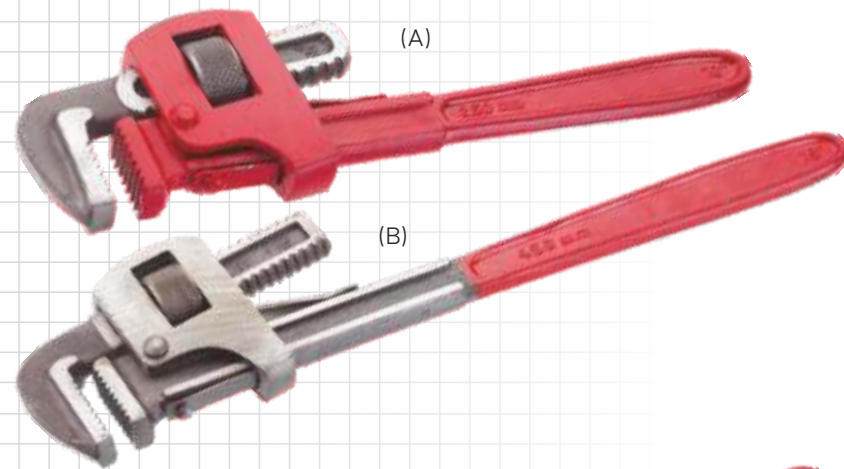

PIPE WRENCH V-163

Stillson pattern Standard

	MM	INCHES	Qty/Ctn/Pcs
(A) Full Paint	200	8	80
(B) Half Paint	250	10	40
	300	12	25
	350	14	20
	450	18	12
	600	24	6
	900	36	4
	1200	48	2

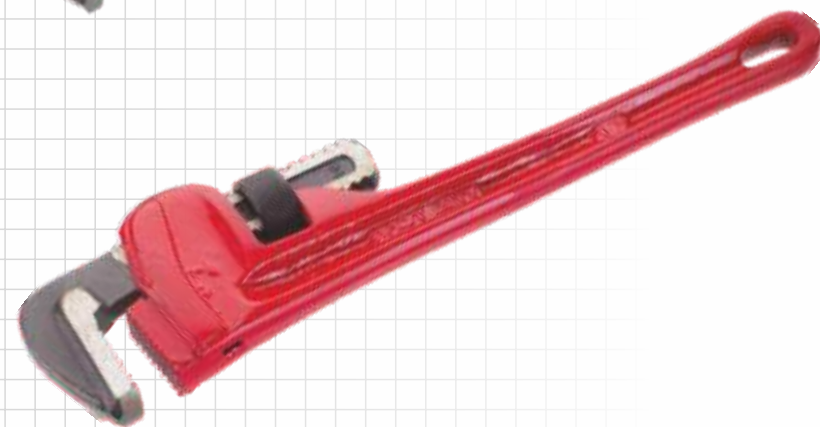

PIPE WRENCH V-164

Heavy duty American pattern

- › Jaws Drop forged from Carbon Steel
- › Malleable Steel Handle

	MM	INCHES	Qty/Ctn/Pcs
	200	8	80
	250	10	40
	300	12	30
	350	14	20
	450	18	16
	600	24	6



PIPE WRENCH V-165

Heavy duty Japanese pattern

- › Drop forged with Steel Housing

	MM	INCHES	Qty/Ctn/Pcs
	200	8	80
	250	10	40
	300	12	30
	350	14	20
	450	18	16
	600	24	6



V-166

CHAIN PIPE WRENCH

- › Steel casted with reversible jaws

	MM	INCHES	Qty/Ctn/Pcs
	50	2	12
	75	3	10
	100	4	8
	150	6	6
	200	8	5
	250	10	3
	300	12	2

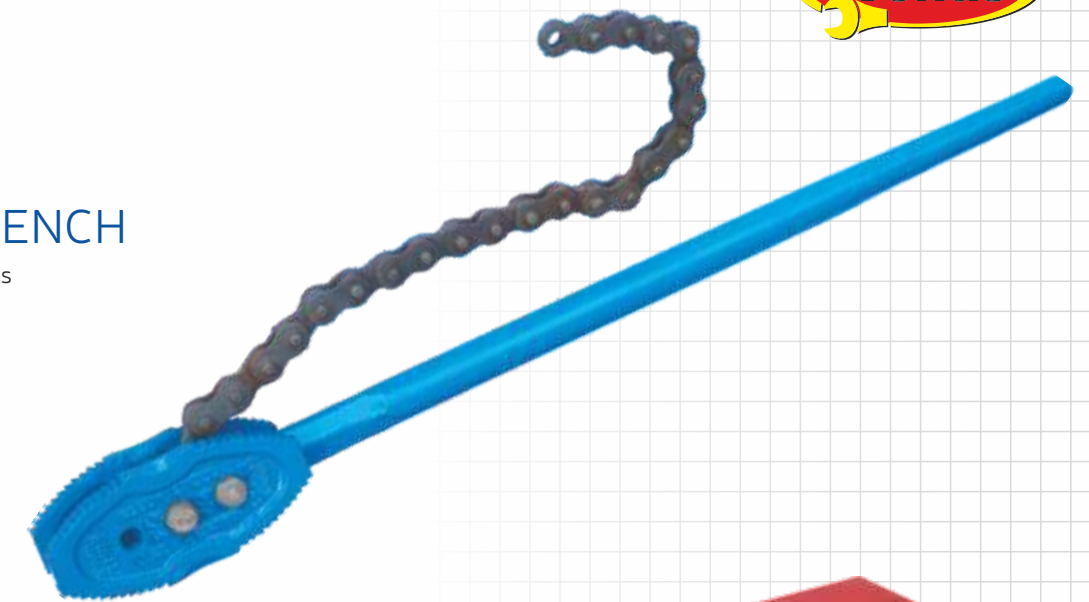

V-167

RATCHET PIPE THREADER SET (WITH RATCHET HANDLE)

- › Vast range of Die set with round dies / 2 pcs dies.
- › High Carbon high chrome collets in an attractive metal box.

INCHES BSP	Qty/Ctn/Pcs
1/2, 3/4, 1	8
1-1/4, 1-1/2, 2	6
2-1/2 3	6
3-1/2, 4	4
5	4
6	4



V-168

PIPE DIE SET WITH PIPE HANDLE THREADING DIES & BUSH

INCHES BSP	Qty/Ctn/Pcs
1/2, 3/4, 1	4
1-1/4, 1-1/2, 2	4
2-1/2 3	2



V-169

THREADING HAND TAPS DIES & HANDLE

	INCHES BSP	Qty/Ctn/Pcs
› Available in all Metric	1/2	100
BSW/UNC/UNF/	3/4	60
BSP specification	1	20
in set and	1/4	60
individual sizes.	3/8	100



A) Round Dies B) Round Die Handle
C) Tap Handle D) Threading Taps





VICES

V-170

ALL STEEL BENCH VICE FIXED BASE

MM	INCHES	Qty/Ctn/Pcs
75	3	6
100	4	4
125	5	2
150	6	2
200	8	1



V-171

ALL STEEL BENCH VICE SWIVEL BASE

MM	INCHES	Qty/Ctn/Pcs
75	3	6
100	4	4
125	5	2
150	6	2
200	8	1



V-172

CAST IRON BENCH VICE FIXED BASE

MM	INCHES	Qty/Ctn/Pcs
75	3	6
100	4	4
125	5	2
150	6	2
200	8	1

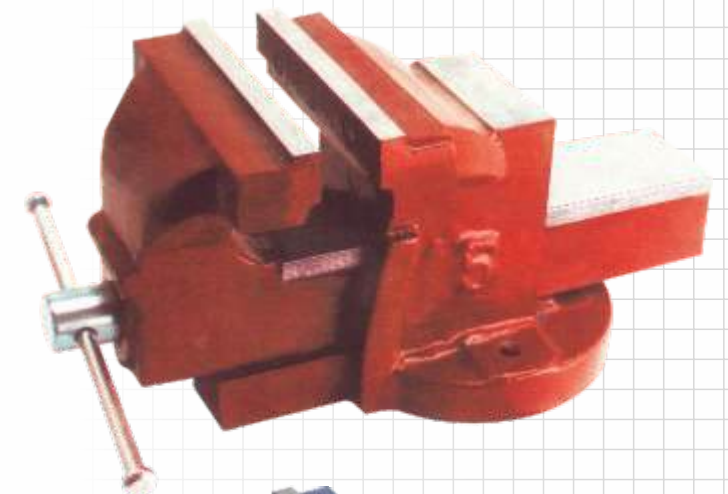

V-173

CAST IRON BENCH VICE SWIVEL BASE

MM	INCHES	Qty/Ctn/Pcs
75	3	6
100	4	4
125	5	2
150	6	2
200	8	1

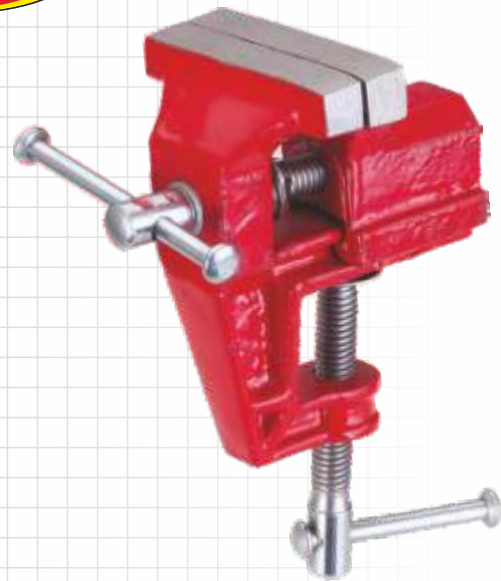

› Vices: Variety of vices fabricated as well as casted are available with hardened carbon steel jaws and chrome plated handles.
› To order plz. specify: A) Fixed/Swivel base B) Net. Wt. C) Colour.

V-174
BABY VICE FIXED BASE

› Sturdy in construction and body made from cast iron. Firm gripping ensures uniform pressure on job.

MM	INCHES	Qty/Ctn/Pcs
40	1-1/2	32
50	2	32
60	2-1/2	24
75	3	24

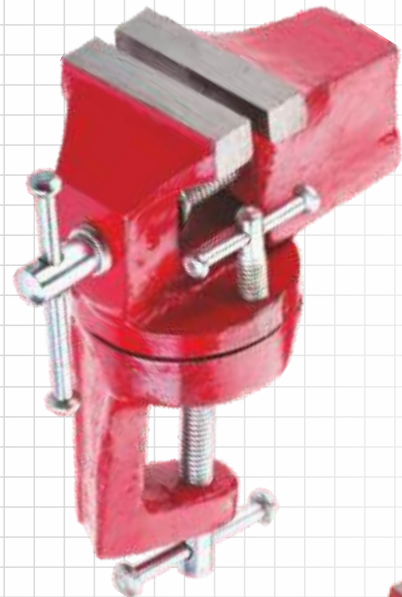
V-175
BABY VICE SWIVEL BASE

› Sturdy in construction and body made from cast iron. Firm gripping ensures uniform pressure on job.

MM	INCHES	Qty/Ctn/Pcs
40	1-1/2	24
50	2	24
60	2-1/2	20
75	3	20

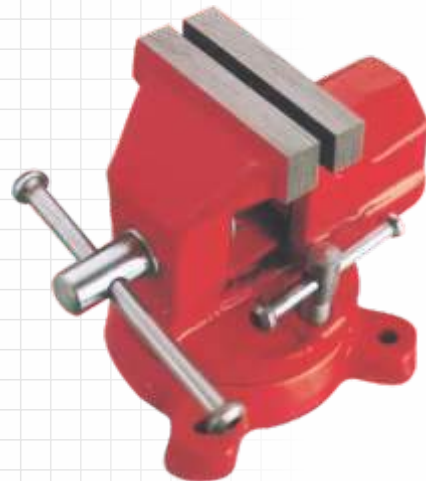
V-176
TABLE VICE SWIVEL BASE

MM	INCHES	Qty/Ctn/Pcs
50	2	16
60	2-1/2	12
75	3	10

V-177
HAND VICE

Convenient for small jobs

MM	INCHES	Qty/Ctn/Pcs
75	3	120
100	4	80
125	5	48
150	6	40
200	8	20

V-178
PIPE VICE SELF LOCKING

› Frame made from malleable iron
› Hardened and Tempered steel jaws

MM	INCHES	Qty/Ctn/Pcs
37	1-1/2	12
50	2	8
63	2-1/2	6
75	3	4
100	4	2

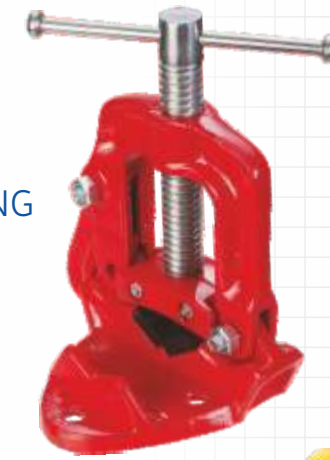
V-179
PIPE VICE Pillar type

› Frame made from malleable iron
› Hardened and Tempered steel jaws

INCHES	Qty/Ctn/Pcs
1/2-2	5 Pcs per Caton

V-180
CHAIN PIPE VICE

› Body made of Cast Iron

MM	INCHES	Qty/Ctn/Pcs
75	3	12
100	4	8
125	5	6
150	6	4
200	8	2

V-181
CAST IRON ANVIL

› Made from selected grade Cast Iron with smoothly machined surface.

LBS	Qty/Ctn/Pcs
0.5	50
1	20
2	12
5	6
10	3
25	1
40	1
50	1



MEASURING TOOLS





EASY SCALE

V-182

CODE	MODEL	SIZE	FEATURE	STD. PKG.
V-182A	ES3	3m x 13mm	without Belt Clip	240 Pcs
V-182B	ES3C	3m x 13mm	w@ith Belt Clip	240 Pcs

IS:1269(PART 2):1997
 * SIZES ISI MARKED
 CLASS II
 CML-4845781

* Standard Color Black
 * Other Colors Available for a minimum order of 25 Cartons



V-SERIES (RIGID ABS CASE)

V-183

CODE	MODEL	SIZE	FEATURE	STD. PKG.
V-183A	V313	3m x 13mm	Belt Clip & Sling without Belt Clip & Sling	240 Pcs 240 Pcs
V-183B	V316	3m x 16mm	Belt Clip & Sling without Belt Clip & Sling	200 Pcs 200 Pcs
V-183C	V519	5m x 19mm	Belt Clip & Sling without Belt Clip & Sling	120 Pcs 120 Pcs

IS:1269(PART 2):1997
 * SIZES ISI MARKED
 CLASS II
 CML-4845781

* Standard Color Black
 * Other Colors Available for a minimum order of 25 Cartons



V-LOCK (RIGID ABS CASE)

V-184

CODE	MODEL	SIZE	FEATURE	STD. PKG.
V-184A	VL313	3m x 13mm	With Lock, Belt Clip & Sling	240 Pcs
V-184B	VL316	3m x 16mm	With Lock, Belt Clip & Sling	200 Pcs
V-184C	VL513	5m x 13mm	With Lock, Belt Clip & Sling	120 Pcs
V-184D	VL516	5m x 16mm	With Lock, Belt Clip & Sling	120 Pcs
V-184E	VL519	5m x 19mm	With Lock, Belt Clip & Sling	120 Pcs

IS:1269(PART 2):1997
 * SIZES ISI MARKED
 CLASS II
 CML-4845781

* Standard Color Black
 * Other Colors Available for a minimum order of 25 Cartons



V-GRIP SERIES (RIGID ABS CASE WITH RUBBER)

V-185

CODE	MODEL	SIZE	FEATURE	STD. PKG.
V-185A	VG313	3m x 13mm	With Lock, Grip & Belt Clip	240 Pcs
V-185B	VG316	3m x 16mm	With Lock Grip & Belt Clip	200 Pcs
V-185C	VG519	5m x 19mm	With Lock Grip & Belt Clip	120 Pcs

IS:1269(PART 2):1997
 * SIZES ISI MARKED
 CLASS II
 CML-4845781

* Standard Color Black
 * Other Colors Available for a minimum order of 25 Cartons



TRENDY MEASURING TAPE

V-186

CODE	MODEL	SIZE	FEATURE	STD. PKG.
V-186A	TL313	3m x 13mm	With Lock, Belt Clip & Sling	240 Pcs
V-186B	TL513	5m x 13mm	With Lock Belt Clip & Sling	120 Pcs
V-186C	TL519	5m x 19mm	With Lock Belt Clip & Sling	120 Pcs

IS:1269(PART 2):1997
 * SIZES ISI MARKED
 CLASS II
 CML-4845781

* Standard Color Black
 * Other Colors Available for a minimum order of 25 Cartons



LONG STEEL MEASURING TAPE

V-187

CODE	SIZE	STD. PKG.
V-187A	10m x 13mm	100 Pcs
V-187B	15m x 13mm	60 Pcs
V-187C	30m x 13mm	40 Pcs

* Standard Color Grey
 * Other Colors Available for a minimum order of 50 Cartons

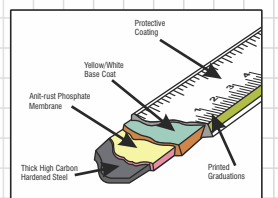



V-188
RAPID MEASURING TAPES

CODE	SIZE	STD. PKG.
V-188A	5m	100 Pcs
V-188B	7.5m	100 Pcs
V-188C	10m	100 Pcs
V-188D	15m	60 Pcs
V-188E	20m	60 Pcs
V-188F	30m	40 Pcs
V-188G with Handle	50m	20 Pcs



Extra Strong Durable Body

IS:1269(PART 1):1997

* SIZES ISI MARKED

CLASS III
CML-4845680

* Standard Color Grey
* Other Colors Available for a minimum order of 50 Cartons

Easy to grip



V-189
ULTRA FIBRE MEASURING TAPES

CODE	SIZE	STD. PKG.
V-189A	15m	100 Pcs
V-189B	30m	100 Pcs

IS:1269(PART 1):1997

* SIZES ISI MARKED

CLASS III
CML-4845680



IS:1269(PART 1):1997

* SIZES ISI MARKED

CLASS III
CML-4845680

V-190
OPEN REEL FIBRE MEASURING TAPE

- Flexible Fibre Tape
- Lock Function with Handle
- Tough & Durable Design
- Non Slippery Rubber Grip
- Innovative Design to maximize ease of use

CODE	SIZE
V-190A	30m
V-190B	50m
V-190C	100m

* Standard Color Grey
* Other Colors Available for a minimum order of 50 Cartons

V-191
PLASTIC MEASURING TAPE

Measuring Range	0-9999.9m
Dia of Wheel	318mm
Expansion Link	560mm-1050mm
Weight	1.52 Kgs.
Color	Yellow, Black
Rod	Steel Pipe, Folding Rod



V-192
MEASURING DIGIWHEEL

Measuring Range	0-99999.9M/FT
Memory Storage	5 Times
Measuring Accuracy	+ .0.5%
Dia of Wheel	159mm
Weight	0.75Kgs.
Expansion Link	690-1120mm



V-193
TRY SQUARE

- › Blade made from hardened spring steel
- › Blade and beam are precisely ground for straightness & parallelism.
- › Available with graduation in inches /mm

MM	INCHES	Qty/Ctn/Pcs
75	3	500
100	4	200
150	6	100
200	8	50
250	10	30
300	12	20



V-194
BEVEL SQUARE

- › Blade made from hardened spring steel

MM	INCHES	Qty/Ctn/Pcs
200	8	120
300	12	100



V-195A
DEPTH GAUGE

INCHES	Qty/Ctn/Pcs
6	400
12	400



V-195B
VERNIER CALIPER

- › Size 6" 150mm
- › 8" 200mm
- › Also available in Steel/Brass

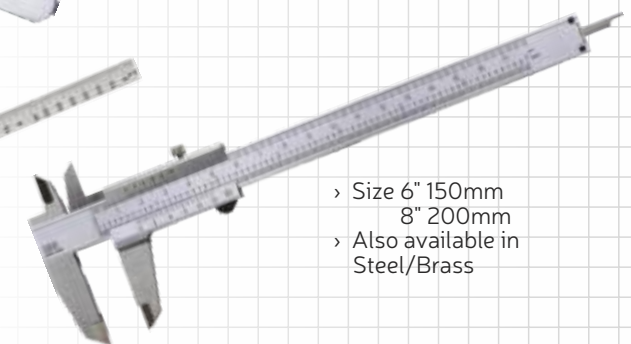

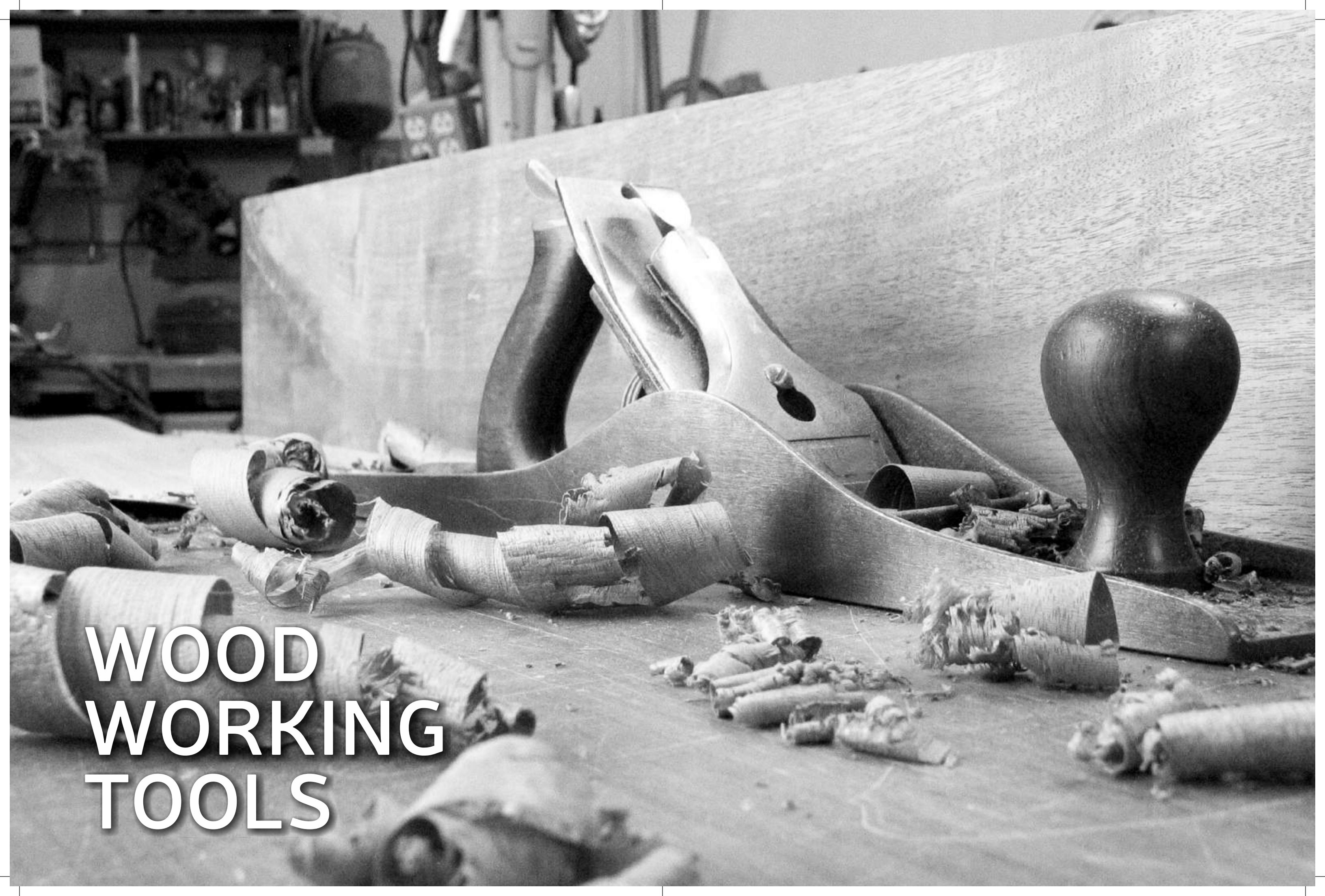

WOOD WORKING TOOLS



V-196

JACK PLANE (Plain Base)

- * Made from fine grey iron casting with bottom machined and ground smooth.
- * Blade of high carbon alloy steel duly hardened.
- * Handle and knob of selected superior wood chemically treated. Also available in PVC handle.

No.	MM	INCHES	Qty/Ctn/Pcs
3	200	8	20
4	225	9	16
5	350	14	10
6	450	18	8
7	550	22	8



V-197

JACK PLANE (Corrugated Base)

- * Made from fine grey iron Casting
- * Groove base helps in stock removal in confined areas
- * Blade of higher carbon alloy steel duly hardened.
- * Handle and knob of selected superior wood chemically treated.

No.	MM	INCHES	Qty/Ctn/Pcs
3	200	8	20
4	225	9	16
5	350	14	10
6	450	18	8
7	550	22	8



V-198

BLOCK PLANE (Sheeted)

- * Made from Steel sheet
- * High Carbon steel body duly hardened & tempered.

MM	Qty/Ctn/Pcs
140	100



V-199

BLOCK PLANE (Casted)

- * Made from fine grey iron casting
- * High Carbon steel body duly hardened & tempered.

MM	No.	Qty/Ctn/Pcs
140	102	60
175	110	40

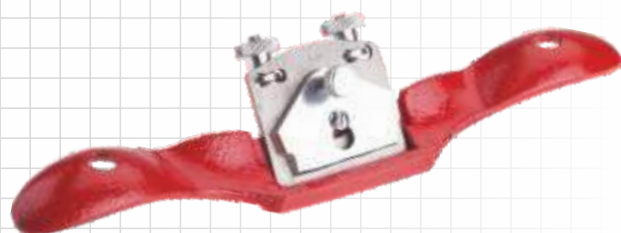

V-200

SPOKE SHAPE

- * Body made malleable iron with hardened cutting blade

MM	Qty/Ctn/Pcs
45	120
50	120



V-201

BREAST DRILL MACHINE

- * Cast Iron Frame Two separate steel pinion with three jaws chuck duly treated for firm grip.

MM	INCHES	Qty/Ctn/Pcs
10	3/8	12
12	1/2	12



V-202

HAND DRILL MACHINE

- * Cast iron frame with gear and pinion teeth machine cut.
- * Double pinion gears for smooth operation.
- * Three jaws chuck for firm gripping.

MM	INCHES	Qty/Ctn/Pcs
6	1/4	24
10	3/8	24



V-203

3 PIECES MINI G-CRAMP SET

- * Malleable iron frame.
- * High quality steel screw chrome plated.

INCHES	Qty/Ctn/Pcs
1,2,3	80

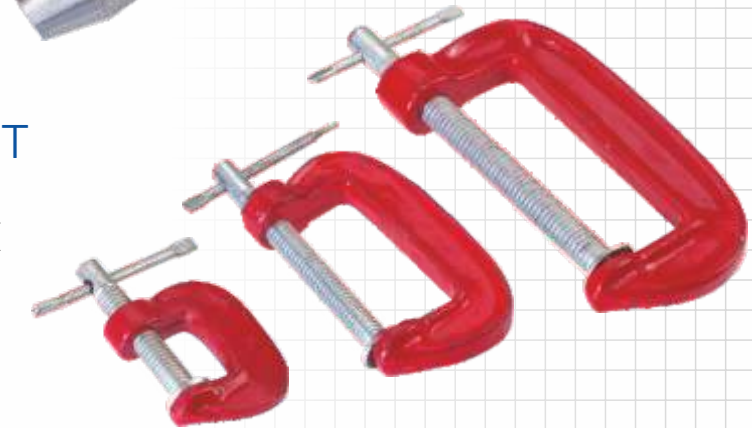

V-204

G-CRAMP

- * Made of malleable iron with finely machined threads for greater clamping force. High quality steel screw chrome plated.
- * Also available in SG Casting.

MM	INCHES	Qty/Ctn/Pcs
50	2	60
75	3	40
100	4	30
150	6	20
200	8	20
250	10	12
300	12	8



V-205

T-BAR CRAMP

- * Malleable jaws on 'T' bar section finely machined to ensure easy sliding and firm grip.

MM	INCHES	Qty/Ctn/Pcs
600	2	10
750	2-1/2	10
900	3	10
1200	4	10
1800	6	10
2100	7	6
2400	8	6

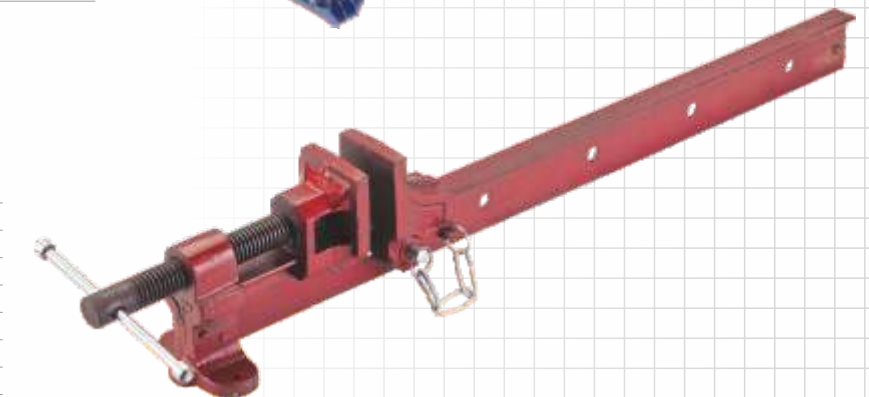

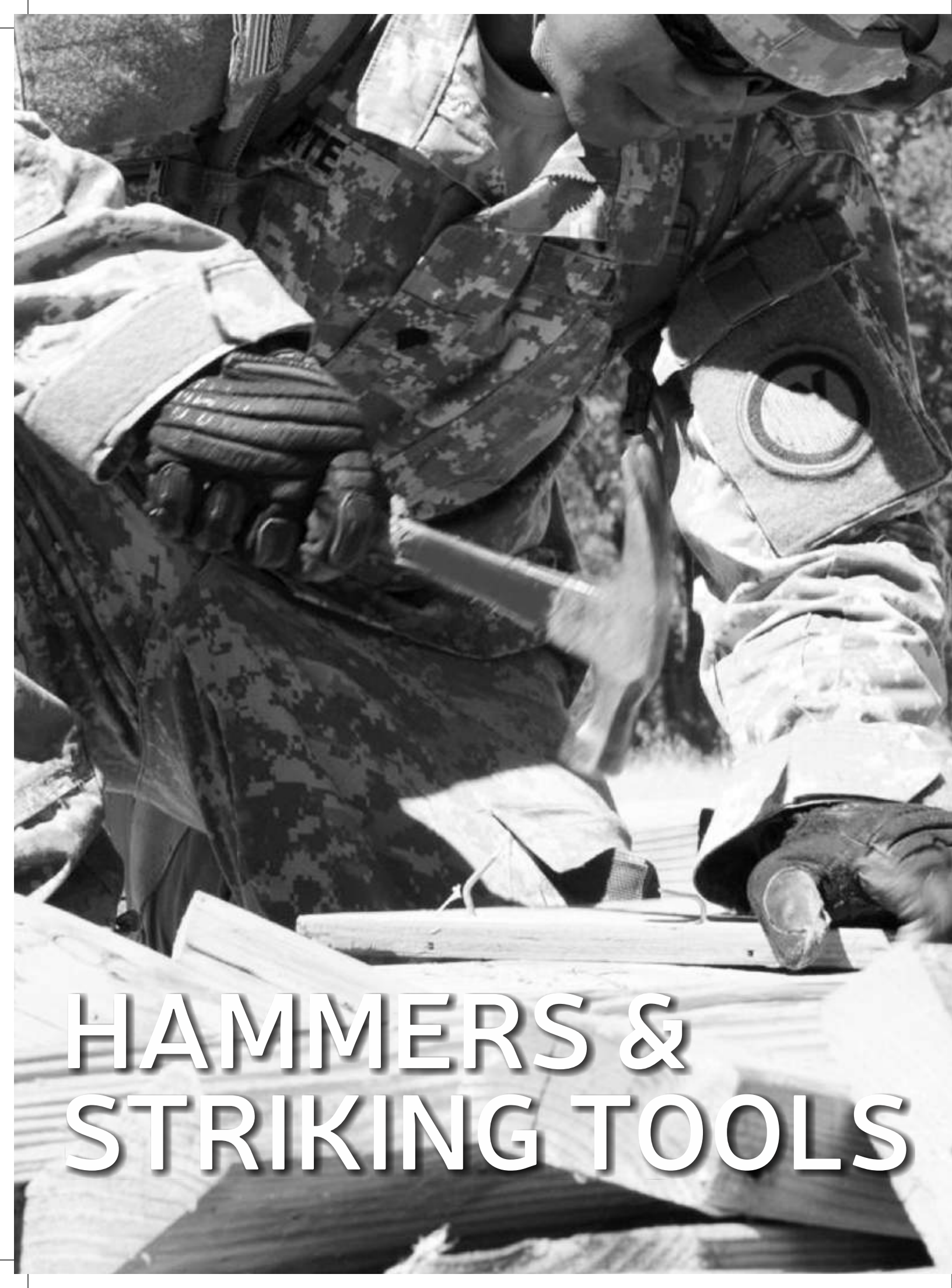

HAMMERS & STRIKING TOOLS

V-206

BALL PEIN HAMMER

- › Drop forged head from carbon steel.
- › Hardened & tempered striking faces.
- › Fitted with seasoned & chemically treated wooden handle.

Size (Gms)	Qty/Ctn/Pcs
100	96
200	72
300	60
500	48
600	36
800	24



V-207

CROSS PEIN HAMMER

- › Drop forged head from carbon steel.
- › Hardened & tempered striking faces.
- › Fitted with seasoned & chemically treated wooden handle.

Size (Gms)	Qty/Ctn/Pcs
100	96
200	72
300	60
500	48
600	36
800	24



V-208

CLAW HAMMER

- › Drop forged head from selected carbon steel duly hardened & tempered.
- › Claw accurately machined for fine gripping edges
- › Tubular steel handle with rubber grip available.

Size (Gms)	LBS	Qty/Ctn/Pcs
225	1/2	60
450	1	40



V-209

MACHINIST HAMMER

- › Drop forged head from carbon steel.
- › Hardened & tempered striking faces.
- › Fitted with seasoned and Chemically treated wooden handle.

Size (Gms)	Qty/Ctn/Pcs
100	120
150	120
200	100
250	60
300	60
400	40
500	40
800	24
1000	24

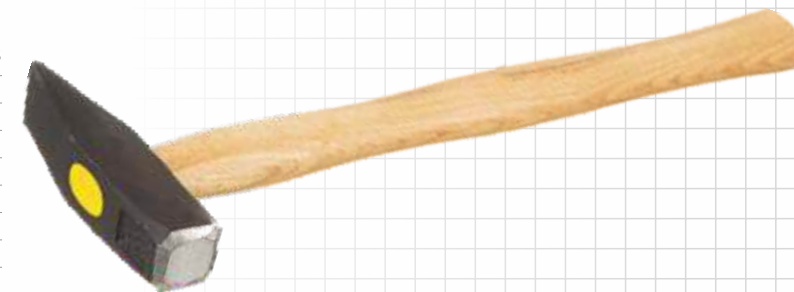

V-210

SOFT FACED HAMMER

Size (MM)	Qty/Ctn/Pcs
20	64
25	64
30	40
40	20
50	20





V-211A
CHIPPING HAMMERS
 with Rubber Handle

Size (Gms)	Qty/Ctn/Pcs
300	100

V-211B
CHIPPING HAMMERS
 with Spring Handle

Size (Gms)	Qty/Ctn/Pcs
300	100

V-212
SLEDGE HAMMERS

- › Drop forged head from carbon steel.
- › Hardened & tempered striking faces.
- › Fitted with seasoned and Chemically treated wooden handle.

Size (Gms)	Qty/Ctn/Pcs
2	50
3	32
4	24
5	20
6	14
8	10
10	8
12	6
14	6
16	6

V-213
CLUB HAMMERS
 A) Wooden Handle
 B) Fibre Handle

- › Drop forged head from carbon steel.
- › Hardened & tempered striking faces.
- › Fitted with seasoned and Chemically treated wooden handle.
- › Also available with fibre glass handle.

Size (Gms)	Qty/Ctn/Pcs
800	24
1000	24
1250	16
1500	16
2000	12

V-214
CROW BAR

- › Selected carbon steel.
- › Hardened & tempered.
- Sizes to order



CHISEL
 (A) FLAT (B) POINTED

* Forged from carbon steel, duly hardened and tempered. Available with/without rubber grip.

MM	INCHES	Qty/Ctn/Pcs
200	8	60
250	10	60
300	12	48
350	14	36
400	16	36

PROFESSIONAL CHISELS

* Forged from carbon steel, duly hardened and tempered.

MM	INCHES	Qty/Ctn/Pcs
200	8	48
250	10	36
300	12	36

BRICK BOLSTER CHISEL

- › Made from carbon steel, Hardened & Tempered.
- › Available with or without rubber guard

MM	INCHES	Qty/Ctn/Pcs
60	2-1/4	60
115	4-1/2	24

MASON'S PEG

- › Available in Octagonal / Round body

MM	INCHES	Qty/Ctn/Pcs
250	10	120

WRECKING BAR

- (A) Double bend
- (B) Single Bend

MM	Qty/Ctn/Pcs
16 x 450	24
16 x 500	24
16 x 600	24
18 x 450	20
18 x 500	16
18 x 600	16
18 x 700	12
18 x 750	12

- › Hot forged from carbon steel
- › Hardened & tempered

© Nail Puller Double Bend with Grip.

MM	Qty/Ctn/Pcs
10 x 12	36
12 x 12	36
10 x 16	36
12 x 16	36





LUBRICATION TOOLS

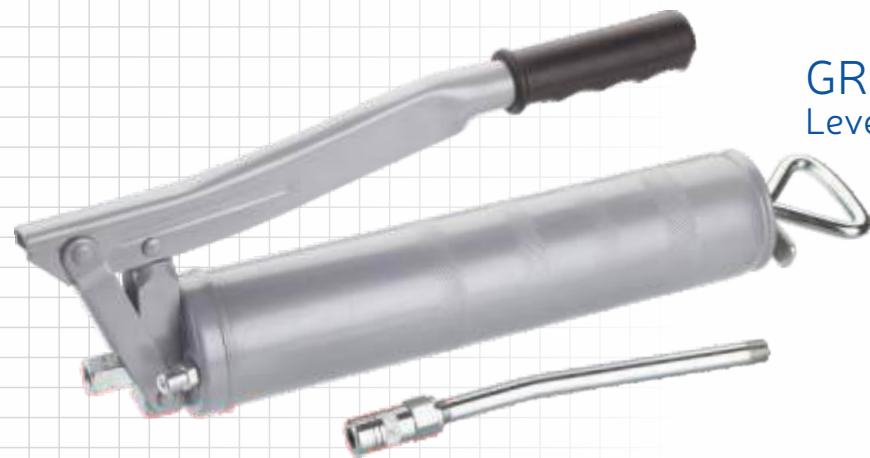

GREASE GUN Lever type

V-220

- › Ideal for industrial & automobile applications.
- › Powder coated finish end, also available with die casted head.
- › Fitted with rigid metal spout with coupler.

OZ	CC	QNTY/CTN/PCS
4	100	40
8	170	25
10	285	25
15	445	10

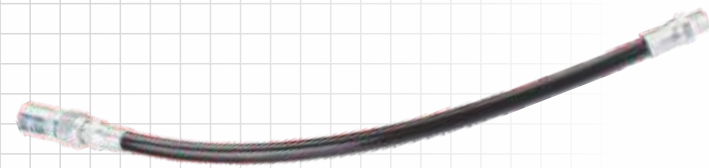

FLEXIBLE HOSE with / without coupler

V-221

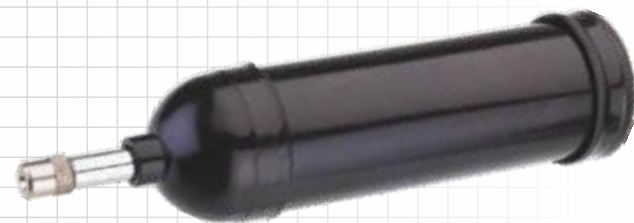

GREASE GUN Lever type

V-222

- › Suitable for soft and medium grease action
- › Available in different finish.

OZ	CC	QNTY/CTN/PCS
4	112	80
8	225	50



HIGH PRESSURE OIL CAN Wesco Type

V-223

- › Metal body oil can with steel pumps for proper oil impinge.
- › Available with fixed or flexible spout.

PINT	QNTY/CTN/PCS
1/4	200
1/2	100
3/4	100
1	100
1-1/2	60
2	60



HIGH PRESSURE OIL CAN Perfetto Type

V-224

- › Metal body oil can with steel pumps for proper oil impinge.
- › Available with fixed or flexible spout.

CC	QNTY/CTN/PCS
1200	100
300	100
400	100
500	100
700	60
1000	60



V-225

ROTARY BARREL PUMP

MM	Qnty/Ctn/Pcs
90	6
100	6

V-226

BUCKET GREASE PUMP

- * Quick and easy openable cover.
- * Adjustable carry handle.
- * Minimum delivery rate 8gms/stroke.
- * Maximum delivery rate 12gms/stroke.
- * Working pressure up to 3500 PSI.
- * 1/4 * 12 * 1.5meter wire braided, oil resistance high pressure hose.
- * Lever operated pump mounted on cover of drum.
- * Spring loaded disc is placed inside the drum to make positive pressure or easy pumping of grease.

Code no.	Capacity	Discription
A	3kg	without Wheel
B	5kg	without Wheel
C	6kg	without Wheel
D	8kg	without Wheel
E	10kg	without Wheel
F	12kg	with/without Wheel
G	15kg	with/without Wheel
H	16kg	with/without Wheel
I	20kg	with/without Wheel
J	24kg	with/without Wheel



V-227

POLYETHYLENE MEASURES

- * Chemical & oil resistant.
- * Resistant to extreme weather condition.
- * Durable Construction.
- * One Hand Operated.
- * With flexible spout with or without dust cover.
- * Calibrated life line.

Warning : It should not be used with hot engine or gear boxes.

Code no.	Capacity
A	1Ltr.
B	2Ltr.
C	3Ltr.
D	5Ltr.



OTHER TOOLS



SCREW DRIVERS

V-228 Engineer's Pattern

MM	Qty/Ctn/Pcs
2.5x50	400
3.5x75	400
4.5x100	400
4.5x150	400
4.5x200	400
6x100	200
6x150	200
6x200	200
6x250	100
8x150	100
8x200	100
8x250	100
8x300	100
10x200	60
10x250	60
10x300	60
10x350	60
10x400	60
10x450	60

V-229 Screw Driver Reversible (2 in 1)

MM	Qty/Ctn/Pcs
6x100	200
6x250(Insulated)	100
6x150	200
6x150(Insulated)	200
6x200	200
5x75	200
6x100	200

V-233 Screw Driver Kit

Flat blade 3, 5, 6mm
Philips head no 0, 1, 2
Round poker and extension rod
Neon bulb tester (500V)

V-230 Philips Head

MM	Qty/Ctn/Pcs
3.5x65	400
3.5x100	400
3.5x150	400
4.5x75	400
4.5x100	400
5x75	200
6x100	200
6x150	200
6x200	200
8x250	100

V-231 Electricians Pattern (with Insulation)

MM	Qty/Ctn/Pcs
3.5x100	400
3.5x150	400
4.5x100	400
4.5x150	400
5x100	400
5x150	200
5x200	200
5x250	100

V-232 Screw Driver Kit

Flat blade 3, 5, 6mm
Philips head no 0, 1, 2
Round poker and extension rod
Neon bulb tester (500V)

V-234 Screw Driver Kit

Flat blade 3, 5mm
Philips head no 0, 1
Round poker

V-235 STRIKING SCREW DRIVER

MM	Qty/Ctn/Pcs
8X150	100
8x200	100
8x250	100
8x300	100

V-236 ALLEN KEYS

Chamfered heads
Chrome Vanadium Steel
Black Finish
Fully heat treated 48-52HRC

MM	INCHES	DISCRIPTION
1.5mm	1/16	100
2mm	5/64	100
3mm	3/32	100
4mm	1/8	100
5mm	3/16	50
6mm	7/32	50
8mm	1/4	50
10mm	5/16	25
12mm	3/8	25
14mm	1/2	10
17mm	9/16	10
19mm	5/8	10

V-237 ALLEN KEY (9Pcs. Set)

Chamfered heads
Chrome Vanadium Steel
Black Finish
Fully heat treated 48-52HRC

mm- 1.5,2,2.5,3,4,5,6,8,10
Inch-1/16,5/64,3/32,1/8,5/32,3/16,1/4,5/16,3/8

Set	Qty/Ctn/Pcs
9 Pcs.	50

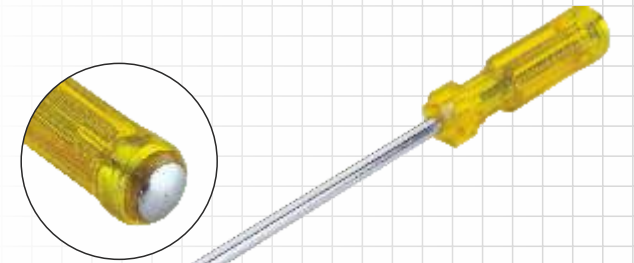
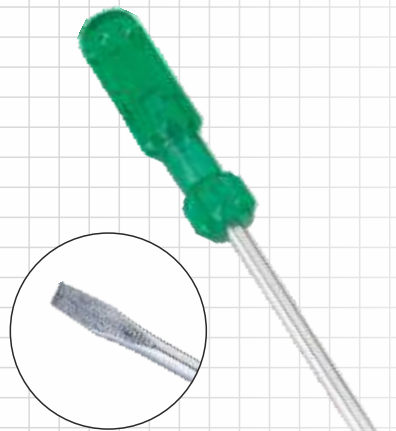



STEEL FILES

Product Name	Size	
	MM	INCHES
Slim Taper	100	4
Slim Taper	125	5
Slim Taper	150	6
Regular Taper	100	4
Regular Taper	150	6
Heavy Taper	150	6
Heavy Taper	200	8
Mill Bastard	250	10
Flat S/L Bastard	250	10
Flat S/L II Cut	250	10
Flat Handle Bastard	250	10
Flat Handle II Cut	250	10
Flat Bastard	150	6
Flat Bastard	208	8
Flat Bastard	250	10
Flat Bastard	300	12
Half Round Bastard	150	6
Half Round Bastard	200	8
Half Round Bastard	250	10
Half Round Bastard	300	12
Square Bastard	250	10
Round Bastard	150	6
Round Bastard	200	8
Round Bastard	250	10



LETTER PUNCHES

- * Letters (A to Z) capital (& sign) with 27 pcs. set.
- * Fully hardened and tempered.
- * Packing: Plastic Box/Tin Box
- * Stamp Size: To Order.



FIGURE PUNCHES

- * Figures: 0 to 9(9 Pcs.).
- * Fully hardened & tempered.
- * Packing: plastic box/ tin Box.
- * Stamp size: To Order.

PIN PUNCH

- * Made out of special carbon steel.
- * Duly hardened & tempered.
- * Size: To Order

CENTRE PUNCH

- * Special carbon steel body duly hardened & tempered.
- * Sizes : To Order.

NAIL PUNCH

- * Special carbon steel body duly hardened & tempered.
- * Knurled body available for secure grip.
- * Sizes : To Order.

V-238

V-244

HACKSAW

Tubular Frame With Plastic Handle

MM	INCHES	QNTY/CTN/PCS
300	12	48

V-245

HACKSAW

Tubular Frame With Steel Handle Adjustable

MM	INCHES	QNTY/CTN/PCS
300	10-12	48

V-246

JUNIOR HACKSAW

(A) Steel Handle (B) Plastic Handle

(A) › Made from steel wire with blade

MM	INCHES	QNTY/CTN/PCS
150	6	300

(B) › With plastic handle for comfortable grip and available in different colours & design

MM	INCHES	QNTY/CTN/PCS
150	6	150

V-247

HAND SAW

12" Blade with Plastic Handle

INCH.	CC	QNTY/CTN/PCS
10-12	300	48

MM	INCHES	QNTY/CTN/PCS
300	12	48

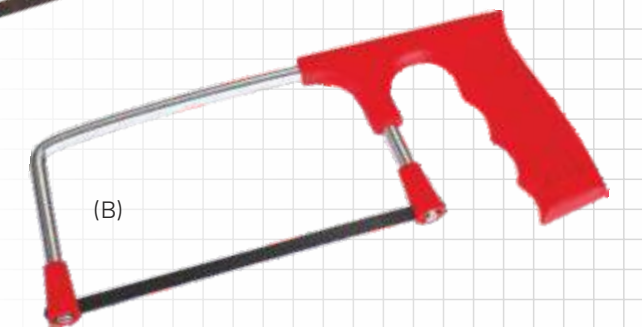
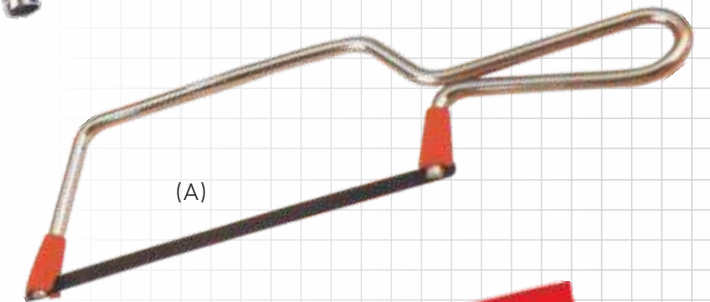
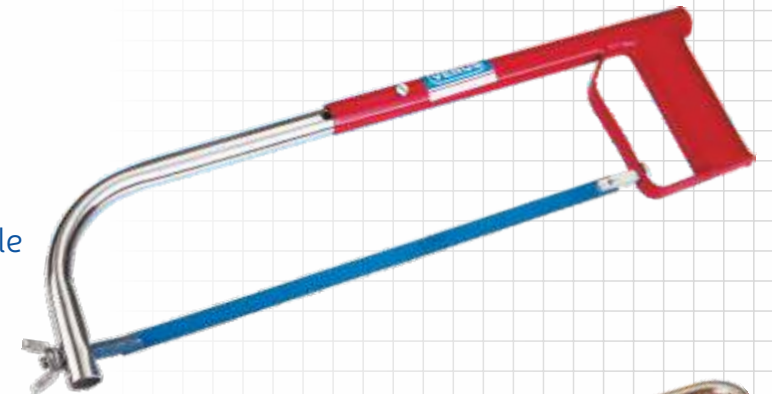



10 Pocket Leather Tool Kit

V-248

- * Two Large main pockets.
- * Two medium size front nail pockets.
- * Six small pockets
- * One side holster.
- * Double stiched With reinforced reverting for added strength.
- * Two leather hammer loops.
- * Adjustable belt with plastic/metal buckle.



High Quality Combination Leather Tool Kit

V-249

- * Two Large main pockets.
- * Two medium size front nail pockets.
- * Six small pockets
- * One side holster.
- * Double stiched With reinforced reverting for added strength.
- * Two leather hammer loops.
- * Adjustable belt with plastic/metal buckle.



10 Pocket Leather Tool Kit (Economy)

V-250

- * Two Large main pockets.
- * Two medium size front nail pockets.
- * Six small pockets
- * One side holster.
- * Two leather hammer loops
- * Adjustable belt with plastic/metal buckle.



10 Pocket Professional Style Nail & Tool Bag

V-251

- * One Large main pockets.
- * Two medium size front pockets with metal tape holder.
- * Six small pockets
- * One side holster.
- * Two belt level inner pockets.
- * Two leather hammer loops
- * Wide belt tunnel slot.



5 Pocket Leather Carpenter Apron

V-252

- * One Large main pockets.
- * One medium size nail pockets with metal tape holder.
- * Three small tool pockets.
- * One leather hammer loop.
- * Adjustable Belt With plastic/metal buckle.



5 Pocket Leather Carpenter Apron

V-253

- * One Large main pockets.
- * One medium size nail pockets with metal tape holder.
- * Three small tool pockets.
- * With steel hammer holder
- * Adjustable Belt With plastic/metal buckle.

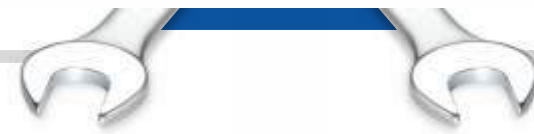

V-254

Leather Nail Bag

- * Available in double/single pocket
- * Superior quality canvas leather
- * Riveted for added strength
- * Adjustable belt with plastic/metal buckle
- * Also available in split leather



V-255

Leather Hammer Holders

- (A) Swinging Loop
- (B) Fixed Loop



Leather Welding Apron

V-256

- * Superior quality split leather
- * Split leather shoulder and waist strap
- * One front top pocket

V-257

Leather Knee Pads

- * Heavy duty leather with thick inner filled for comfort & safety
- * Adjustable nylon stop with plastic buckle



V-258

Leather Tape Holders

- * Leather tap holder designed to hold tapes with safety strap



V-259

Leather Drill Holders

- * Leather Drill Holders Designed to hold Drill with safety strap.





V-260

Trowel (Small)

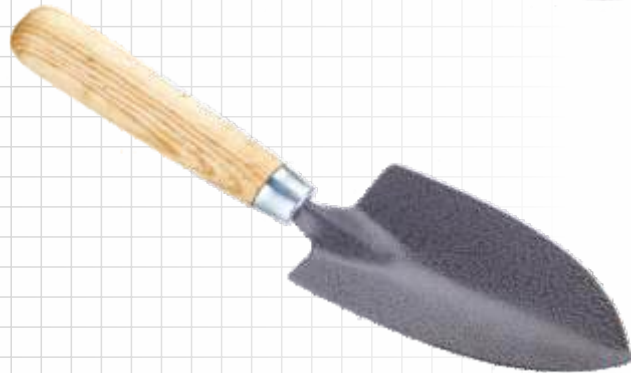

V-261

Hand trowel (Big)



V-262

Hand Fork



V-263

Cultivator



V-264

Weeder

› Standard packing
› Available in Plastic & Wooden Handles

V-265

BORDER FORK

* Made of carbon steel.
* Plastic coated steel cored shaft with handle for grip.

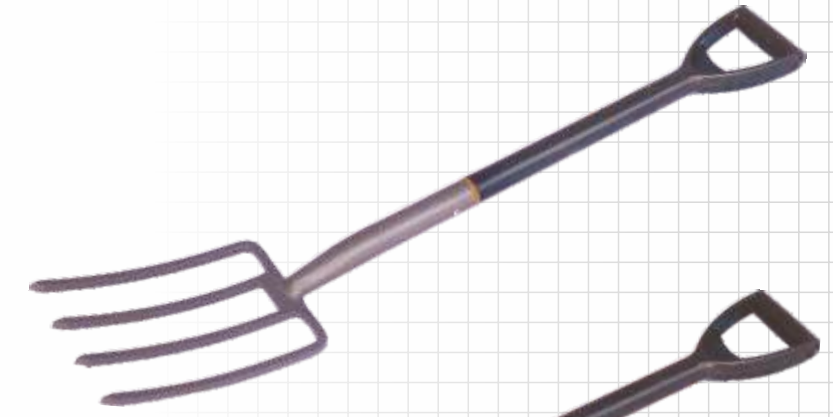

V-266

BORDER SPADE

* Made of carbon steel.
* Plastic coated steel cored shaft with handle for grip.

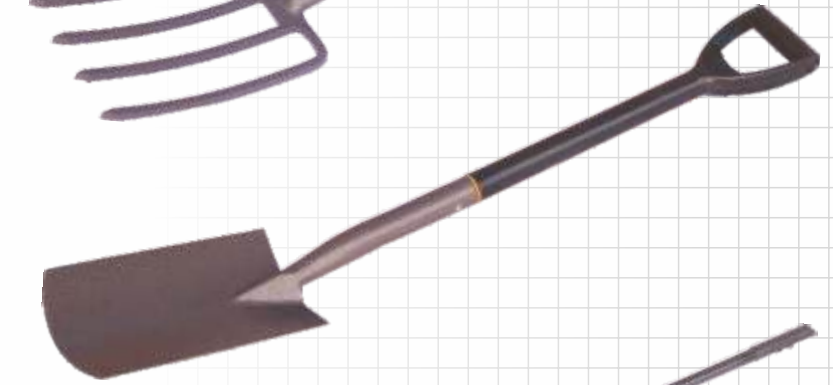

V-267

GARDEN RAKE

* Made from carbon steel sheet.
* Available 8,10,12,14 & 16 teeth
* To order with or without handle.

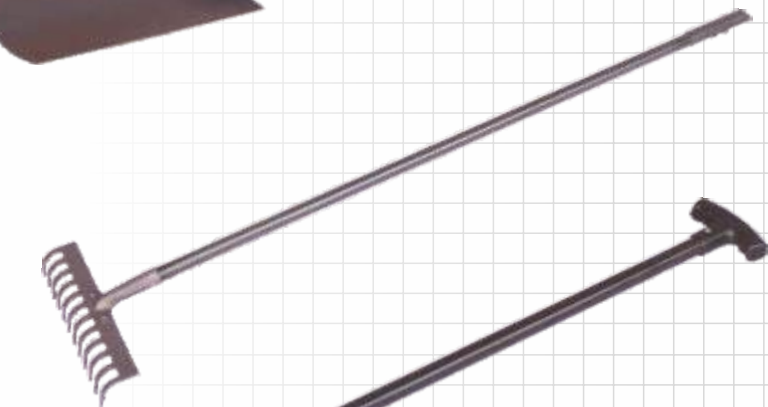

V-268

LEAF RAKE

* Flexible with center support.
* Available in 16/ 22 tins.

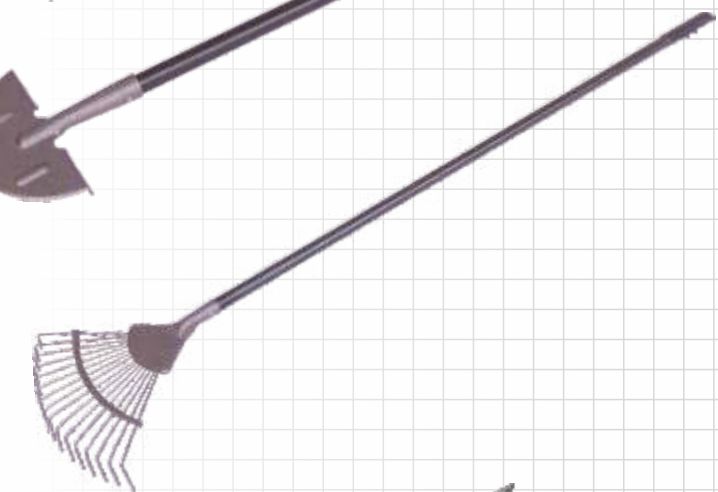

V-269

PICK AXE CHISEL & POINTED

* Made of high carbon steel.
* Edges may be polished or silver painted.
* Available in round or oval eye.

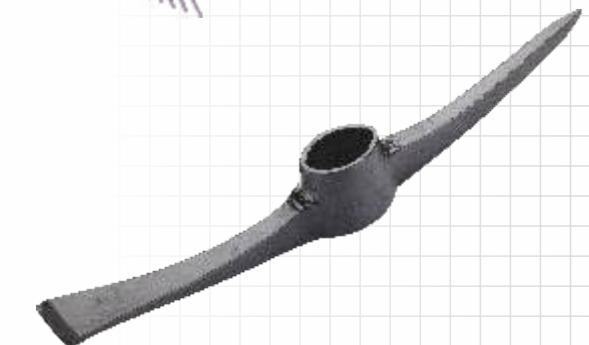



NOTES

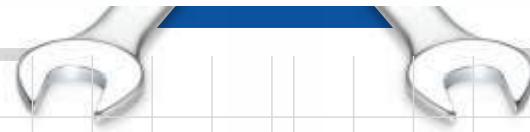

NOTES





NOTES

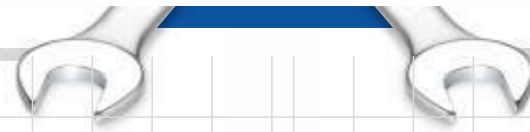

NOTES

